

Refrigerant
R410A
INVERTER

AIRSTAGE™ V-II

Variable Refrigerant Flow System

Multi Air Conditioning System for Buildings

Large Capacity Multi VRF System
DC Inverter Control Compressor
Long Piping System Design
High Efficiency Refrigerant R410A

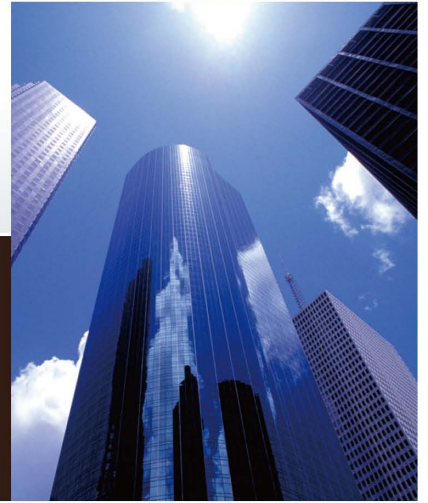

FUJITSU GENERAL LIMITED

All for Comfort

Smart and cutting edge design

Extensive lineup from 8HP to 48HP in 2HP increment

Connectable indoor unit capacity ratio up to 150%



High Efficiency Operating System

EER/COP has been significantly improved by unique inverter technology and refrigerant control technology.



Installation Flexibility

Total pipe length of 1,000m and 150m actual pipe length. From small to large buildings, any application can be supported.



Compact Design

The outdoor unit size has been significantly reduced by optimizing of equipment. This allows for a reduction in the required installation area floor space.



User Friendly Central Control

Diverse building air conditioning control functions can be controlled easily by central air conditioning control.



AIRSTAGE™ V-II
Variable Refrigerant Flow System





INVERTER

CONTENTS

FEATURES

- High Efficiency Operation 4
- Design Versatility 6
- High Reliability 8
- Easy Installation 10
- Comfort and Convenience 12
- Easy Service & Maintenance 14

OUTDOOR UNITS

- Lineup 16
- Specifications 18
- Dimensions 20

INDOOR UNITS

- Lineup 22
- Compact Cassette 24
- Cassette 26
- Compact Duct 28
- Slim Duct 30
- Low Static Pressure Duct / Duct 32
- High Static Pressure Duct 34
- Floor / Ceiling 36
- Ceiling 38
- Compact Wall Mounted 40
- Wall Mounted 42

CONTROLLER

- Control System 44
- Wiring System 46
- Comparison table of Controllers 47
- Wired Remote Controller 48
- Simple Remote Controller 49
- Wireless Remote Controller 50
- IR Receiver Unit 51
- IR Receiver Kit 51
- Group Remote Controller 52
- Central Remote Controller 54
- Touch Panel Controller 56
- System Controller (Software) 58

CONVERTOR & ADAPTOR

- Network Converter 62
- Network Converter for LONWORKS® 63
- BACnet® Gateway (Software) 64
- Signal Amplifier 65
- External Switch Controller 65

SERVICE & MONITORING

- Service Tool (Software) 66
- Web Monitoring Tool (Software) 68

OTHERS

- Energy Recovery Ventilator 70
- Fujitsu General Supports Diverse
- VRF System Design 72
- Optional Parts 73



FEATURES

Advanced system considers high efficiency operation

High Efficiency Operation



Energy saving technology that boosted operation efficiency



Powerful large propeller fan

By using CFD*1 technology, A newly designed fan achieves high performance and low noise operation.

*1. CFD = Computational Fluid Dynamics



DC fan motor

Power consumption has been reduced by 25% compared to previous models by using a compact and high performance DC fan motor.



Subcool heat exchanger

High Heat Exchange efficiency is achieved by using an internal projection shape double pipe construction.



Sine-wave DC inverter control

High efficiency operation is realized by using a sine wave DC inverter control.



DC twin rotary compressor

Significantly greater efficiency is realized by use of a large capacity DC twin rotary compressor with substantially increased refrigerant intake and compression efficiency.



4-face heat exchanger

Heat exchange efficiency is significantly improved by the introduction of a new 4-face heat exchanger that increases effective surface area.

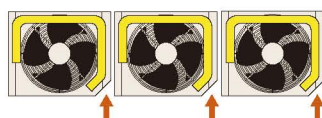

Front intake port (corner cut air inhaling structure)

In multiple outdoor unit installations, the unique front intake design improves airflow into the Heat Exchanger.

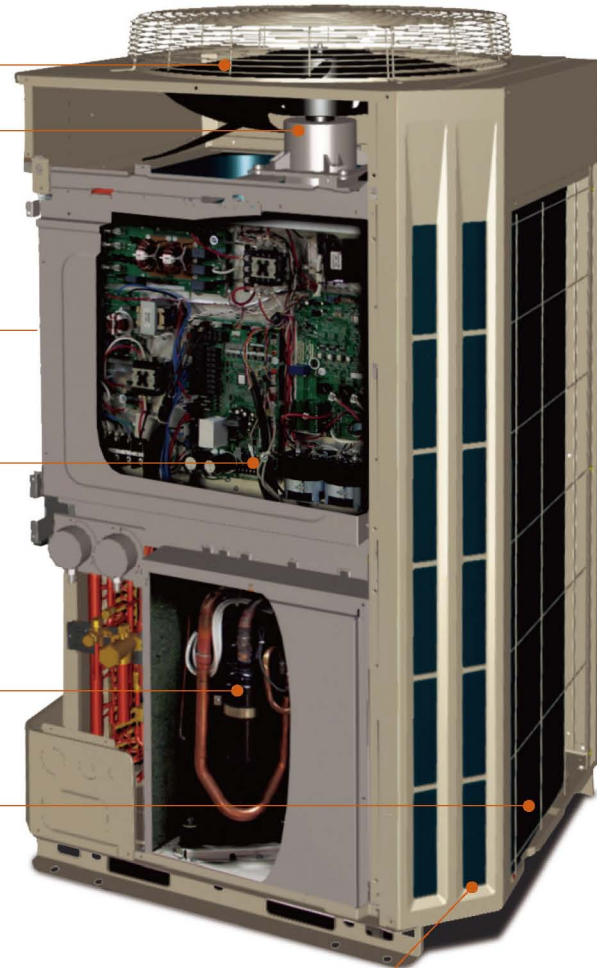

Significantly improved EER/COP

Significantly greater efficiency is realized by the use of a DC twin rotary compressor, inverter technology, and large heat exchanger.

* "EER/COP" is the coefficient of performance
 [= capacity (kW) ÷ input power (kW)].
 *EER/COP values are based on our own testing method.
 *2. The data refers to an 8HP outdoor unit.

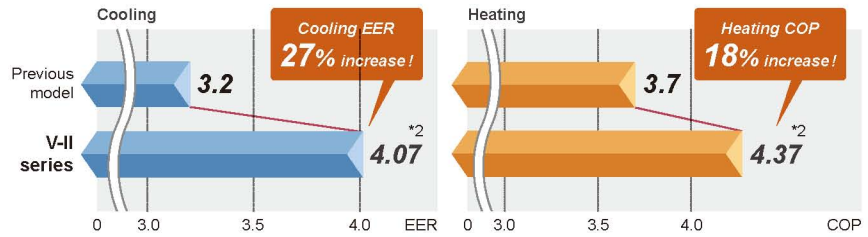

Energy efficiency combination

Choice of space saving or energy efficiency combinations



Various energy saving features

Room temperature set point limitation

The minimum and maximum temperature range can be set giving further energy saving while considering the comfort of the occupants.

Auto-off timer

Each remote controller is equipped with an OFF timer function that automatically stops operation when a fixed time has elapsed from the start of operation. This prevents waste of energy.
 (Note : Except simple remote controller)

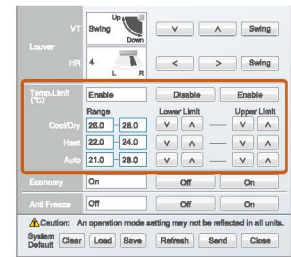
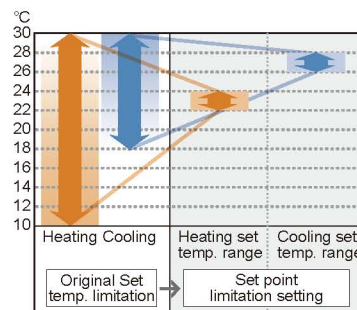

Operation setting (System Controller)

Peak cut operation

Operation capacity can be set in 4 steps for rated capability. The power consumption at peak is cut down and the maximum load is suppressed.

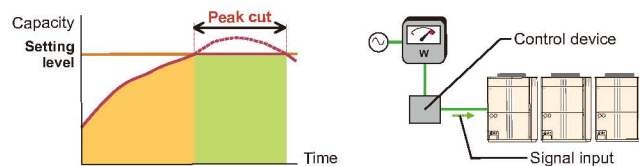

Economy operation

Economy operation can be set by remote controller. The temperature setting is offset automatically over a certain period of time.

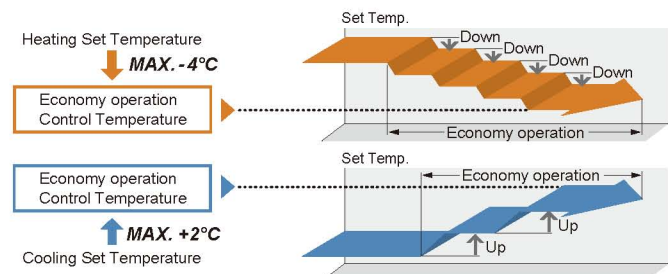

FEATURES

V-II systems can be applied to a wide variety of Building applications due to the reduced outdoor unit size and piping length capabilities

Design Versatility



Overall piping length 1,000m

World's top class overall piping length of 1,000m allows for application in a wide variety of buildings.

Total pipe length
1,000^{*1}m max.

Height difference between outdoor and indoor units
50m max.

For the outdoor unit stated below : 40m max.

High static pressure of 80Pa

The outdoor unit can have a condenser hood easily connected with a static pressure of 80Pa standard. This allows outdoor units to be installed within plant rooms in high rise buildings.

Powerful discharge with an external static pressure of 80Pa.

80Pa
as standard

Previous model

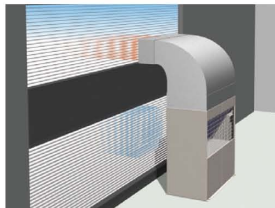

V-II series

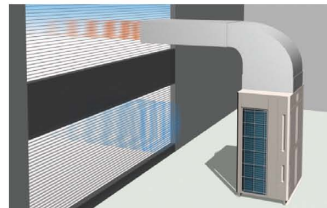

Large diameter fan and DC motor has been utilized allowing an external static pressure of 80Pa. This is approximately 2.6 times greater than the previous model.

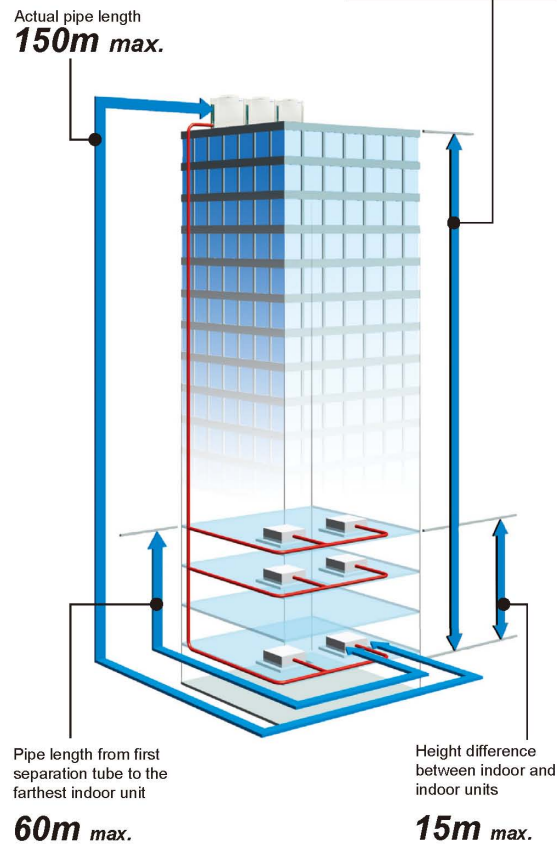
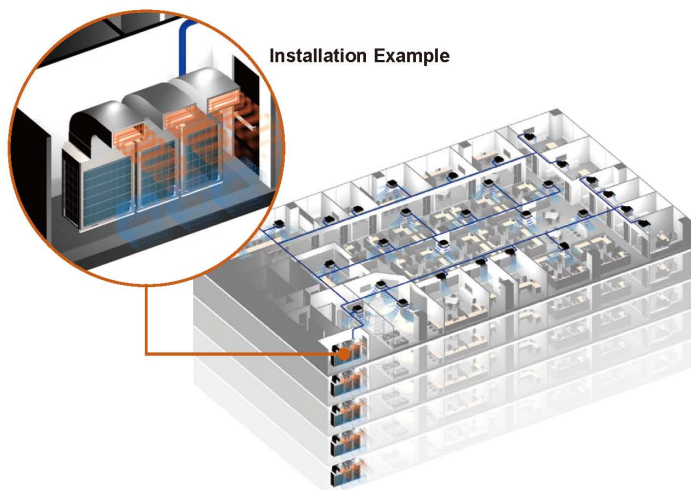

*1. Note : When there is 1 outdoor unit, the maximum is 700m.

Space saving and compact size

Compact size has been achieved by significantly reducing the width of the outdoor units compared to previous models.

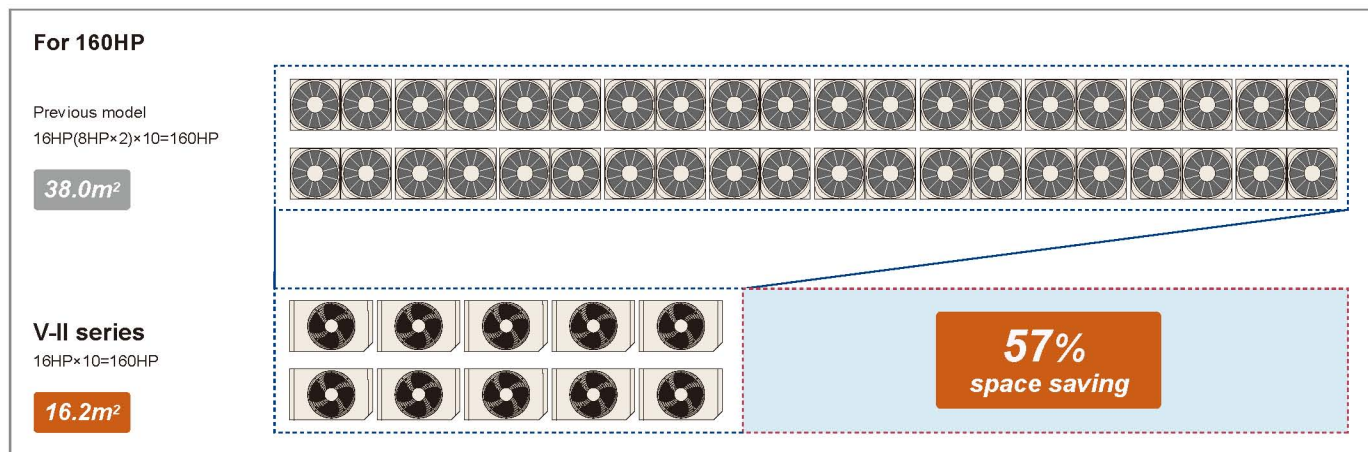

High capacity connection

Various combinations from 8HP to 48HP with 2HP increments. 12 types, 55 models of indoor units can be selected ranging from 2.2kW to 25kW in capacity. A maximum of 150% indoor unit connectable capacity.

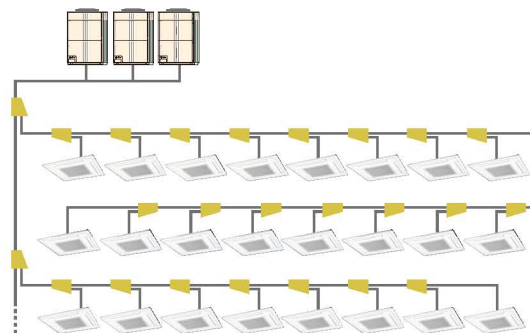

Note : When indoor unit connected capacity is greater than 100%, individual indoor units will operate at a slightly lower capacity when maximum capacity is required.

Wide operating range

Installation in extreme temperature conditions is possible due to an increase in operational range.

Cooling : -15°C~46°C
 Heating : -20°C~21°C

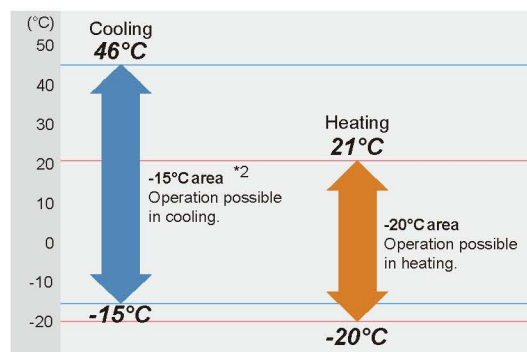

*2. Note : When a multiple outdoor unit connection is used, operating range is from -5°C to 46°C in cooling.

FEATURES

High reliability considering
long-term safety and confidence

High Reliability

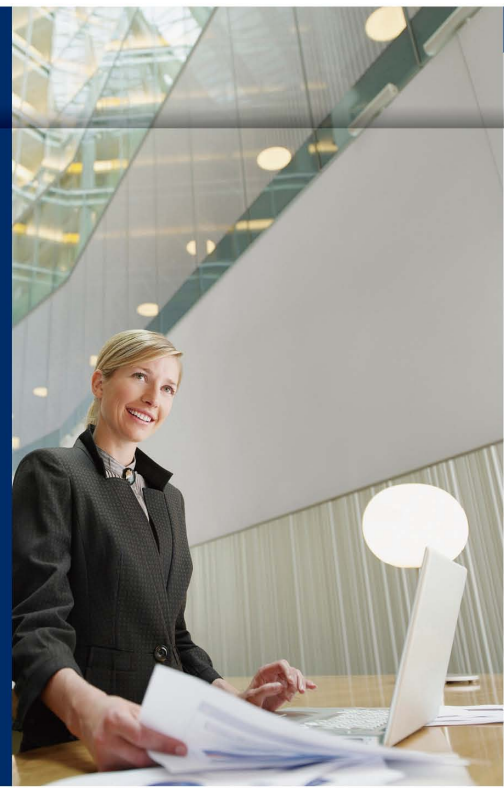

Life-extending operation

Outdoor unit rotational operation

The compressor starting order is rotated so that
the running time is shared.

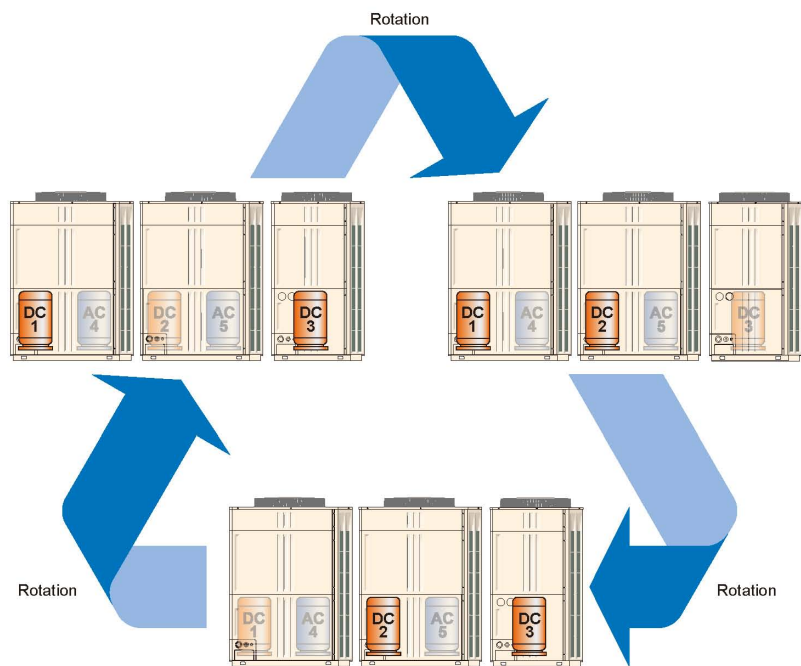
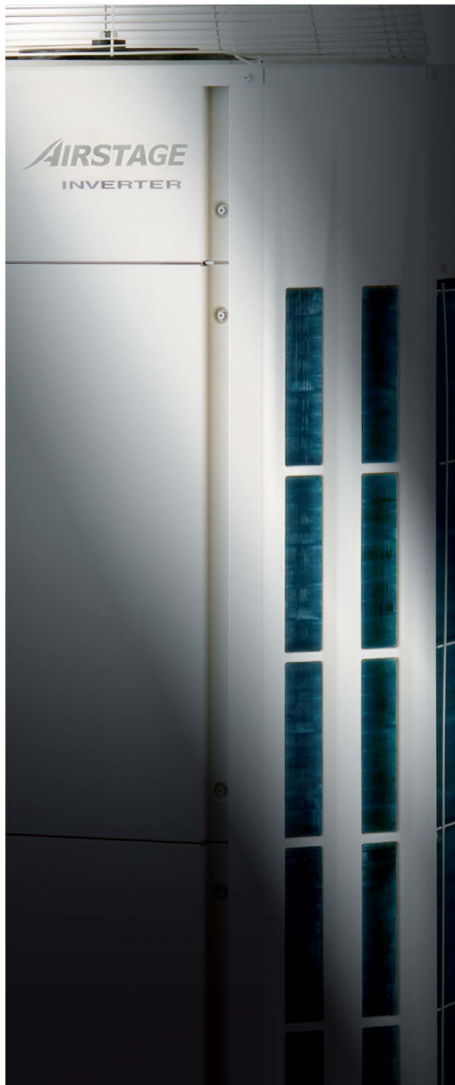

Note: The inverter compressors start in priority.

Rotational operation is alternated by the start / stop timing of the compressors

Backup operation

If one of two compressors malfunctions, it will not affect the operation of the remaining outdoor units.

Outdoor Units

If one of compressor fails, backup operation will be performed by the remaining compressors as emergency.*1

Indoor unit continuous operation

Each indoor unit is controlled individually on the system network. This allows all indoor units to continue to operate unaffected even if an error should occur at any indoor unit's on the VRF network system.

*1 Note: Backup operation may not be possible depending on the combination and trouble state.

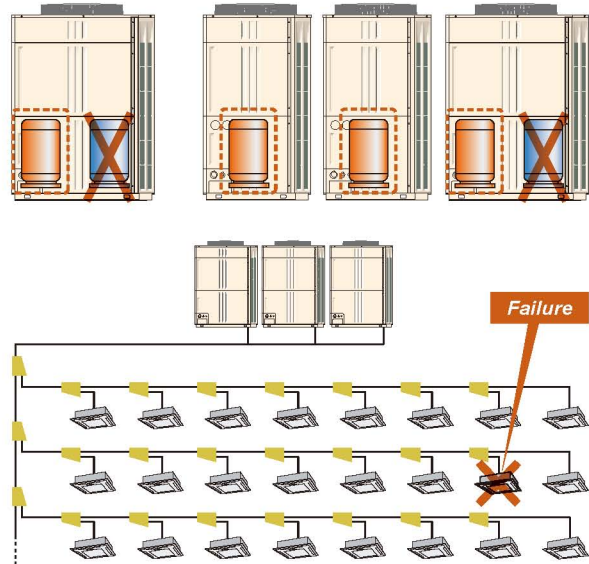

Adoption of blue fin heat exchanger

Corrosion resistant of the heat exchanger has been improved by the introduction of blue fin treatment to the outdoor unit's heat exchanger.

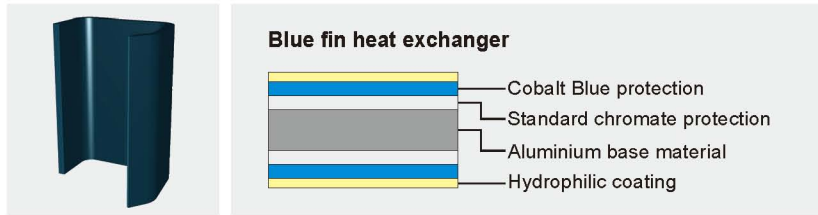

Remote monitoring

The Web Monitoring system allows you view system operation at all times over the internet ensuring trouble free operation.

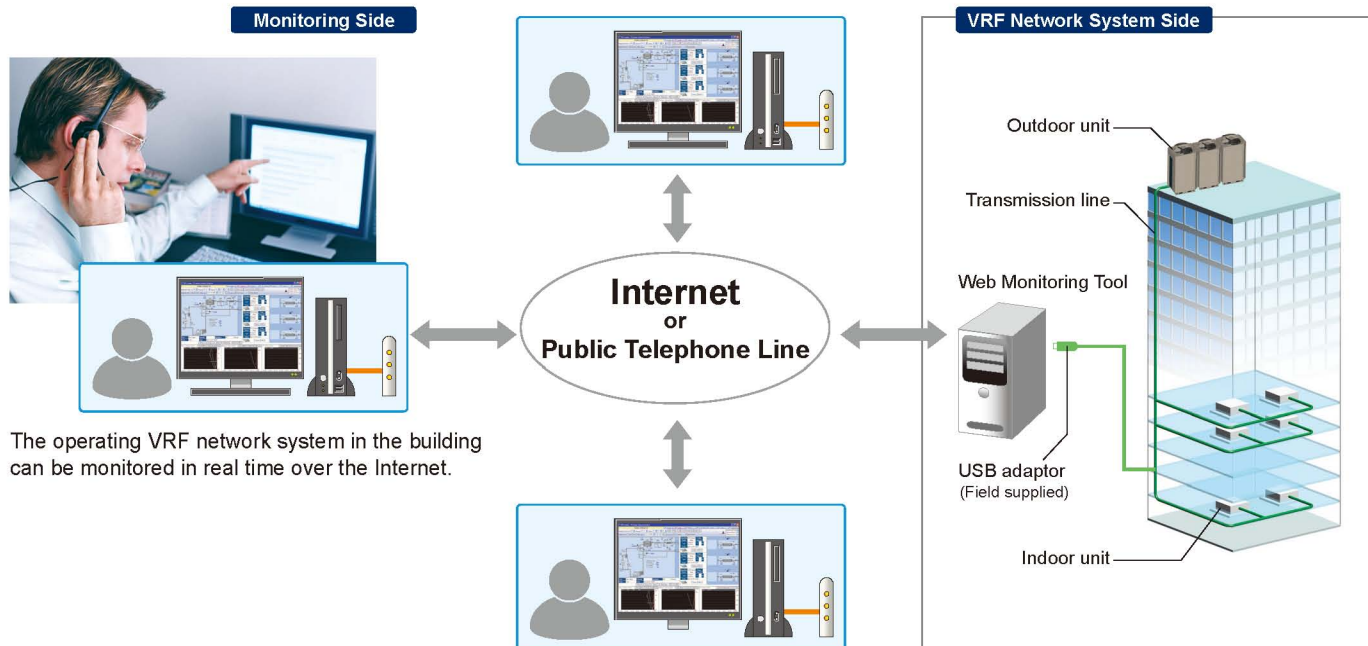

The operating VRF network system in the building can be monitored in real time over the Internet.

FEATURES

From transportation of the product to address setting for commissioning, significant improvements have been made which reduce the cost of installation.

Easy Installation



Easily transported

Light weight



20%
weight reduction
(Than Previous model)

Note: In the case of 14HP

Easily craned using lifting belt hooks

Design of outdoor unit allows for lifting straps to be used



Can be transported in a small elevator



Transporting by forklift

Transport with forklift is possible.

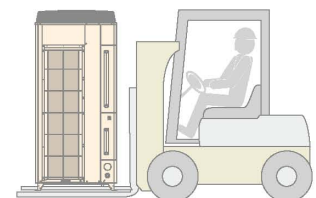

Easy piping connection

The need for an oil equalization pipe as required on the previous model has been removed. The installation costs have been reduced by employing a simple 2 pipe connection

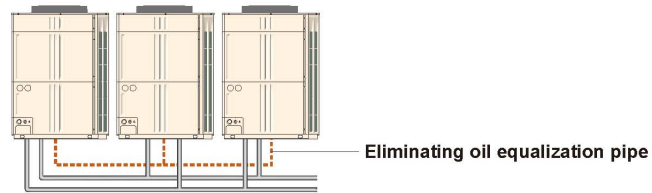

Simple signal line connection

Installation is made easier as the communication wiring can be connected continuously to any component.

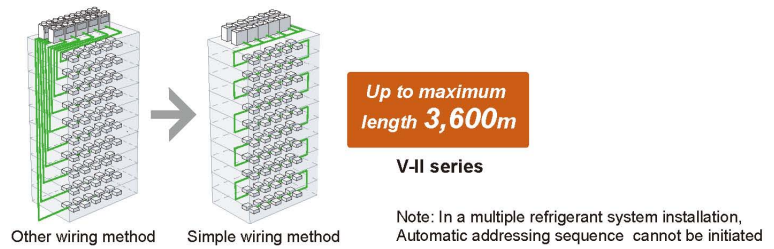

Easy access

By adopting a L-Shape front panel that can be removed, the work space for installation and service has been significantly expanded by this new design. For multiple installations, work is performed easily and efficiently even in a narrow space.

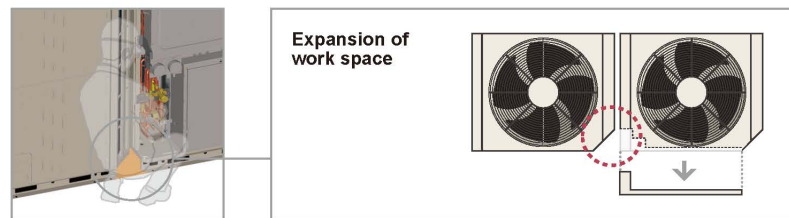

Four way piping connection

Piping and wiring are available to the front, left and right, and bottom.

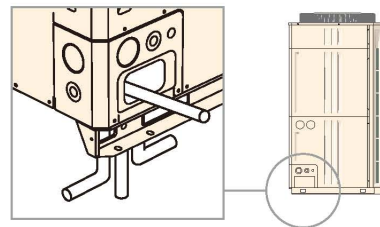

Automatic address setting

The address of each indoor unit can be automatically set by button switch of outdoor unit.

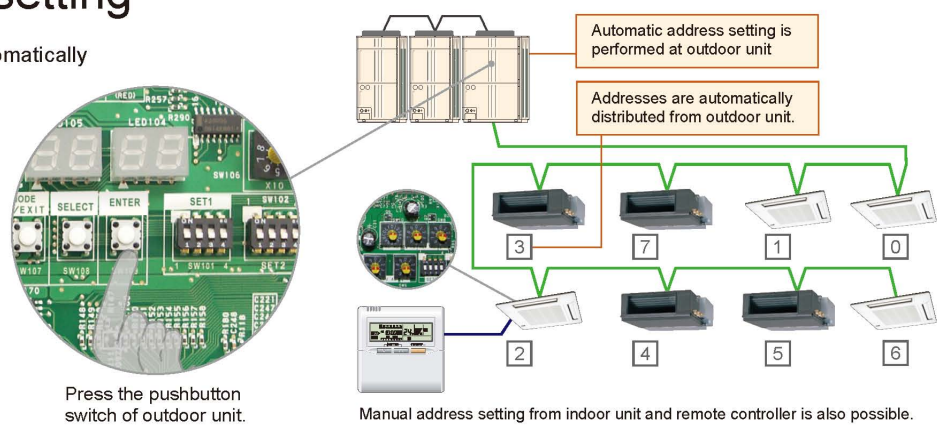

FEATURES

Low noise, easy operational settings, and comfortable temperature adjustment allows for V-II systems to be used in building air conditioning applications.

Comfort and Convenience

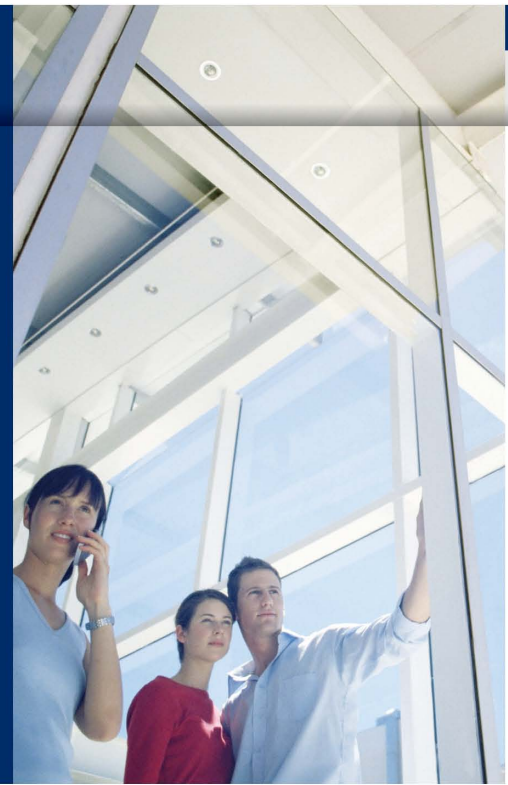

Quiet operation

Low noise mode

Two low noise modes can be selected automatically by quiet priority setting and capacity priority setting depending on the usage environment and outside temperature load.

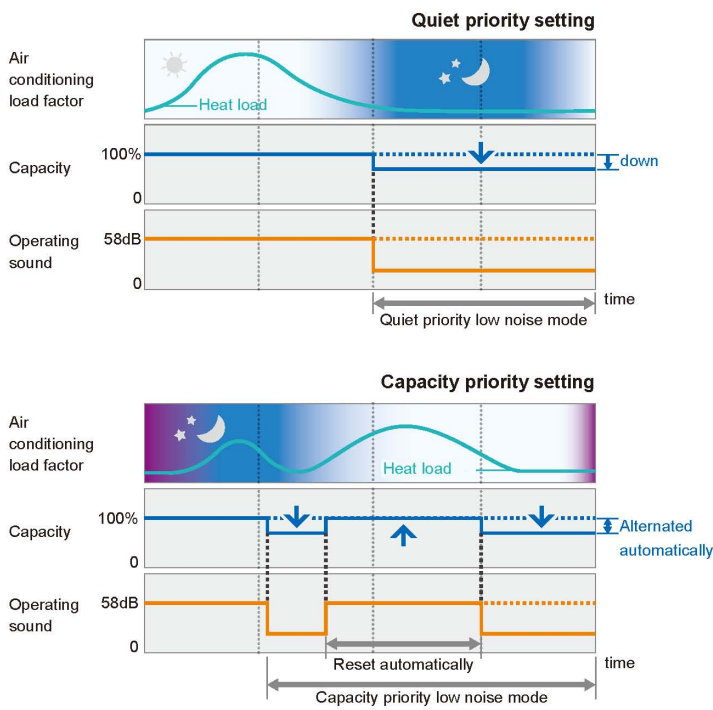

Low noise design

Compressor noise has been significantly reduced by shielding the compressor compartment.

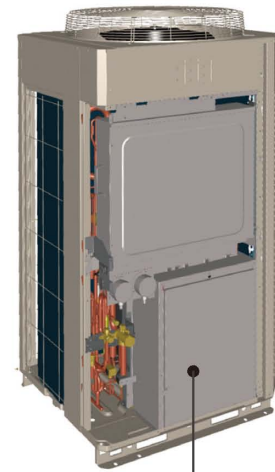

Compressor compartment

Indoor unit

Low noise indoor unit lineup



Compact Cassette



Compact Duct



Slim Duct



Low Static Pressure Duct



Compact Wall Mounted

Auto changeover function

Auto changeover setting allows for the product to easily switch between cooling and heating modes regardless of the operation mode of other indoor units. This can be done via specific indoor unit with wired remote controller. This ensures comfortable operation all year round.

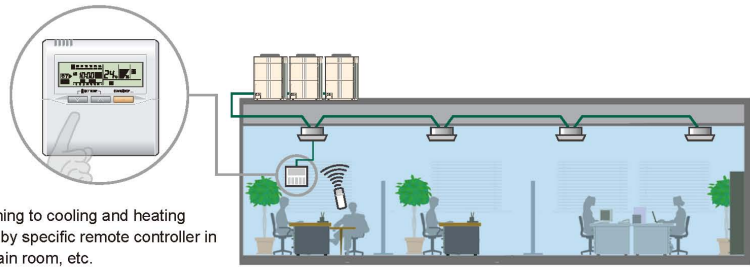

Precision refrigerant flow control

Precision and Smooth refrigerant flow control is achieved by using a DC Inverter control in conjunction with individual indoor unit electronic expansion valve control. This allows for a high precision comfortable temperature control of $\pm 0.5^{\circ}\text{C}$.

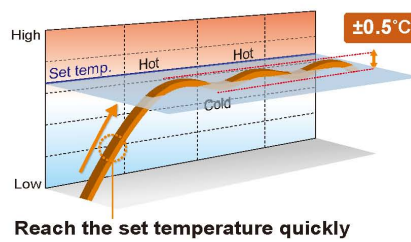

Thermal change of the room
*Simulation in heating operation.
Comfortable operation is achieved due to a small variation of room temperature

Individual air conditioning control

The desired temperature conditions of each room are met due to the Individual thermostat control of each indoor unit.

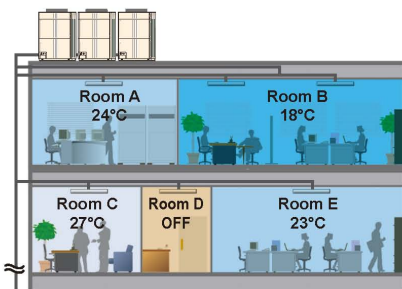

Simple central management function



- Simple central control operation
Simple operation by icon display and color touch screen
- Yearly schedule function
Daily starting & stopping and temperature setting are managed.
- Clock setting function
The clock of each individual controller is periodically corrected.



Non-stop oil recovery operation

A comfortable room condition is maintained during oil recovery mode because the product continues to operate without stopping the cooling or heating operation.

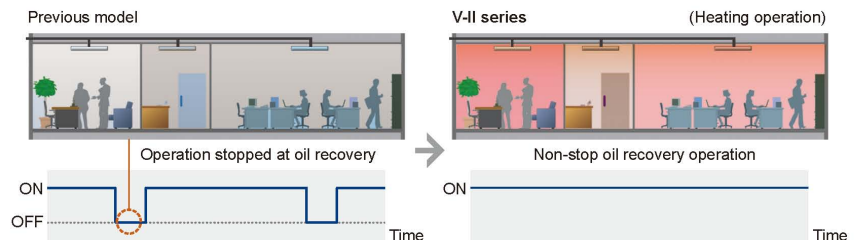

FEATURES

Designed for Quick Service response,
Easy maintenance and Troubleshooting

Easy Service & Maintenance

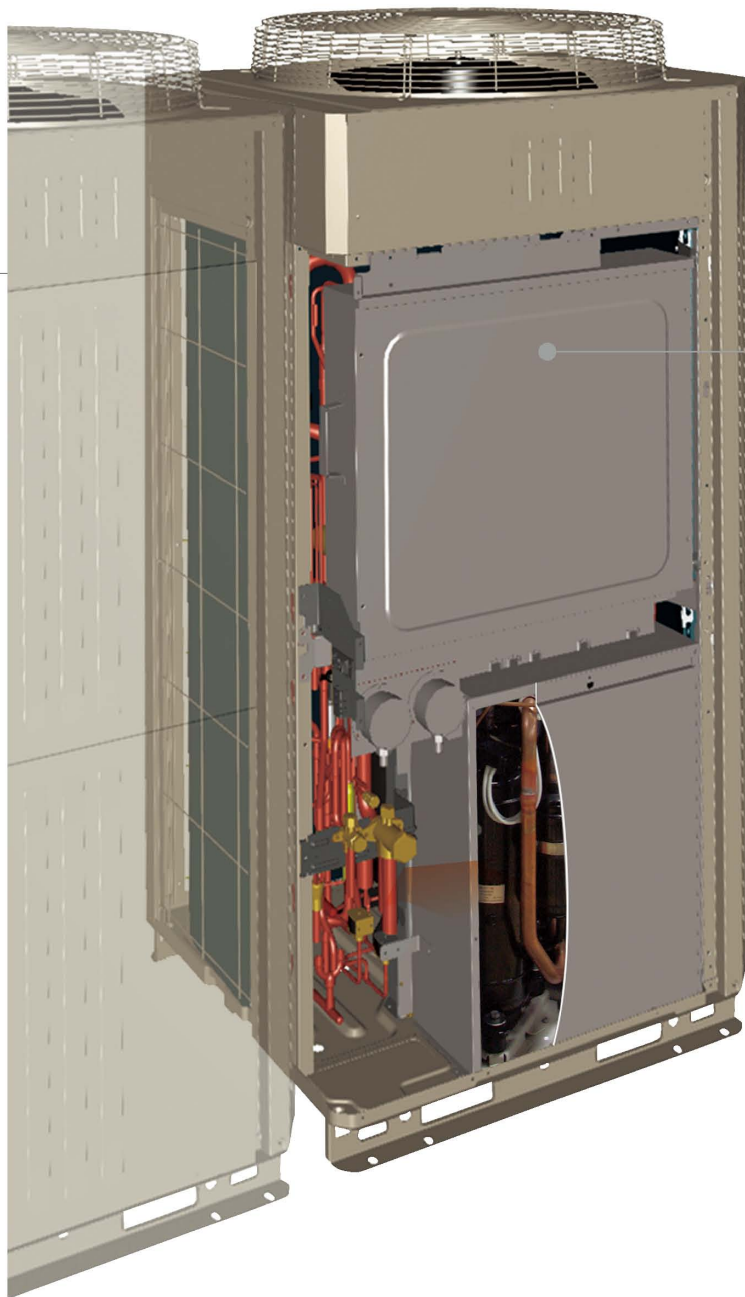

Design for easy service and maintenance

Inspection and replacement of main parts are easier due to innovative construction and an LED operational display.



Consolidated electrical components make maintenance easy
Movable PCB panel that allows for easier maintenance work behind the PCB

Easy-to-read 7-segment LED display which explains operational and trouble status

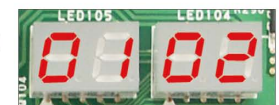

Maintenance of electrical components, valves, and compressor parts from the front is possible.

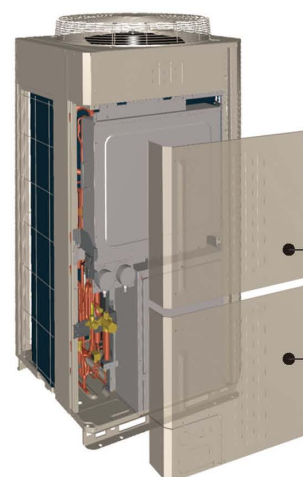

Split front panel
Split front panel allows for maintenance from top or bottom of the outdoor unit

Error status can be checked easily via the indoor unit wired controller

An error code is displayed on a liquid crystal screen.

Wired Remote Controller

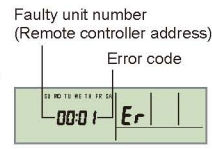

Simple Remote Controller

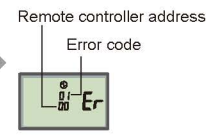

Emergency stop function

Emergency alarm can be received by indoor, outdoor units or Touch Panel Controller when they received it, all units will be stopped.

Note: In case of received Emergency alarm by Indoor / outdoor unit : All units connected within same refrigerant system will be stopped.
Touch Panel Controller : all unit connected within VRF network system with Touch Panel Controller will be stopped.

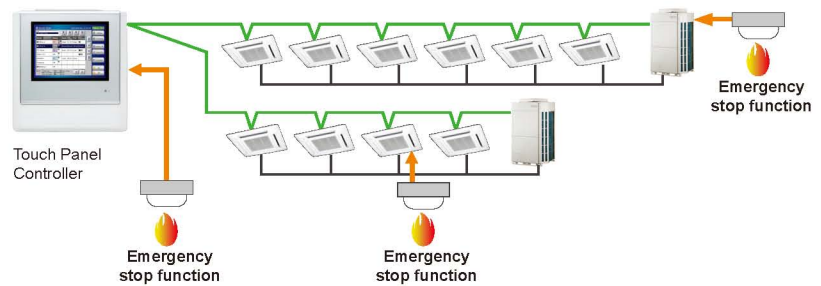

Continuous operation during maintenance

Non-stop operation

When servicing a specific indoor unit, maintenance can be performed even without turning off the other indoor units.

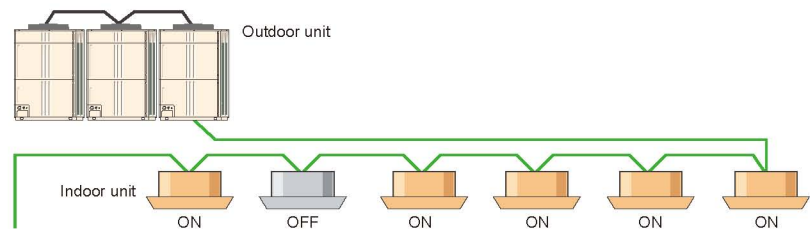

Trouble diagnosis by Service Tool

Suitable maintenance is possible by analysis of the operation data. Connection anywhere in the VRF network is easy.

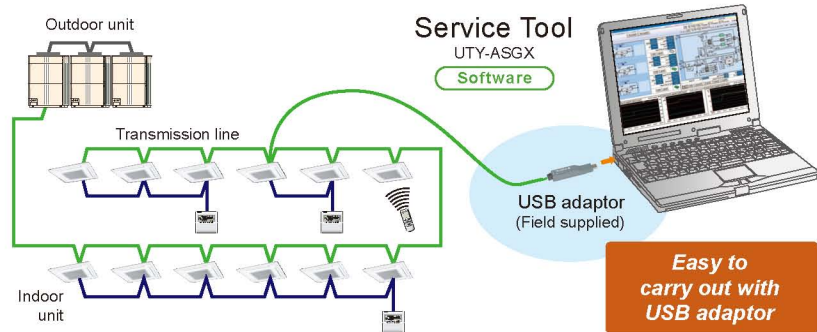

Equipment Detail (Diagram)

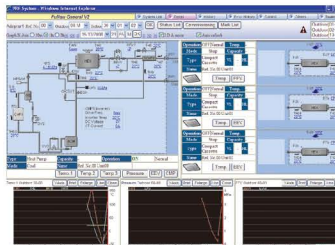

Equipment Detail (List)







No.	Name	Type	Capacity	Control	Model	Area	Unit	Unit	Unit	Unit	Unit	Unit	Unit	Unit	Unit	Unit	Unit	Unit
01	RF Air-Conditioner	Unit	2200	Auto	RF-2200-1	1F	1	1	1	1	1	1	1	1	1	1	1	1
02	RF Air-Conditioner	Unit	2200	Auto	RF-2200-1	1F	2	2	2	2	2	2	2	2	2	2	2	2
03	RF Air-Conditioner	Unit	2200	Auto	RF-2200-1	1F	3	3	3	3	3	3	3	3	3	3	3	3
04	RF Air-Conditioner	Unit	2200	Auto	RF-2200-1	1F	4	4	4	4	4	4	4	4	4	4	4	4
05	RF Air-Conditioner	Unit	2200	Auto	RF-2200-1	1F	5	5	5	5	5	5	5	5	5	5	5	5
06	RF Air-Conditioner	Unit	2200	Auto	RF-2200-1	1F	6	6	6	6	6	6	6	6	6	6	6	6
07	RF Air-Conditioner	Unit	2200	Auto	RF-2200-1	1F	7	7	7	7	7	7	7	7	7	7	7	7
08	RF Air-Conditioner	Unit	2200	Auto	RF-2200-1	1F	8	8	8	8	8	8	8	8	8	8	8	8
09	RF Air-Conditioner	Unit	2200	Auto	RF-2200-1	1F	9	9	9	9	9	9	9	9	9	9	9	9
10	RF Air-Conditioner	Unit	2200	Auto	RF-2200-1	1F	10	10	10	10	10	10	10	10	10	10	10	10

Outdoor Units Lineup









Space saving combination

<p>22.4kW (8HP)</p>  <p>AJ*A72LALH UNIT : AJ*A72LALH</p>	<p>28.0kW (10HP)</p>  <p>AJ*A90LALH UNIT : AJ*A90LALH</p>	<p>33.5kW (12HP)</p>  <p>AJ*108LALH UNIT : AJ*108LALH</p>
<p>55.9kW (20HP)</p>  <p>AJ*180LALH UNIT : AJ*108/A72LALH</p>	<p>61.5kW (22HP)</p>  <p>AJ*198LALH UNIT : AJ*108/A90LALH</p>	<p>67.0kW (24HP)</p>  <p>AJ*216LALH UNIT : AJ*108/108LALH</p>
<p>90.0kW (32HP)</p>  <p>AJ*288LALH UNIT : AJ*144/144LALH</p>	<p>95.0kW (34HP)</p>  <p>AJ*306LALH UNIT : AJ*108/108/A90LALH</p>	<p>100.5kW (36HP)</p>  <p>AJ*324LALH UNIT : AJ*108/108/108LALH</p>
<p>123.5kW (44HP)</p>  <p>AJ*396LALH UNIT : AJ*144/144/108LALH</p>	<p>130.0kW (46HP)</p>  <p>AJ*414LALH UNIT : AJ*144/144/126LALH</p>	<p>135.0kW (48HP)</p>  <p>AJ*432LALH UNIT : AJ*144/144/144LALH</p>

Energy efficiency combination

<p>44.8kW (16HP)</p>  <p>AJ*144LALHH UNIT : AJ*A72/A72LALH</p>	<p>62.4kW (22HP)</p>  <p>AJ*198LALHH UNIT : AJ*126/A72LALH</p>	<p>67.2kW (24HP)</p>  <p>AJ*216LALHH UNIT : AJ*A72/A72/A72LALH</p>
<p>89.8kW (32HP)</p>  <p>AJ*288LALHH UNIT : AJ*108/108/A72LALH</p>	<p>95.9kW (34HP)</p>  <p>AJ*306LALHH UNIT : AJ*126/108/A72LALH</p>	<p>102.4kW (36HP)</p>  <p>AJ*324LALHH UNIT : AJ*126/126/A72LALH</p>

- Extensive line up from 8HP to 48HP in 2HP increments
- Space saving combination and Energy efficiency combination available, which can be selected to suit any air conditioning needs
- Combinations other than the followings are not recommended.



<p>40.0kW (14HP)</p>  <p>AJ*126LALH UNIT : AJ*126LALH</p>	<p>45.0kW (16HP)</p>  <p>AJ*144LALH UNIT : AJ*144LALH</p>	<p>50.4kW (18HP)</p>  <p>AJ*162LALH UNIT : AJ*A90/A72LALH</p>
<p>73.5kW (26HP)</p>  <p>AJ*234LALH UNIT : AJ*126/108LALH</p>	<p>78.5kW (28HP)</p>  <p>AJ*252LALH UNIT : AJ*144/108LALH</p>	<p>85.0kW (30HP)</p>  <p>AJ*270LALH UNIT : AJ*144/126LALH</p>
<p>107.0kW (38HP)</p>  <p>AJ*342LALH UNIT : AJ*126/108/108LALH</p>	<p>112.0kW (40HP)</p>  <p>AJ*360LALH UNIT : AJ*144/108/108LALH</p>	<p>118.5kW (42HP)</p>  <p>AJ*378LALH UNIT : AJ*144/126/108LALH</p>

<p>72.8kW (26HP)</p>  <p>AJ*234LALHH UNIT : AJ*A90/A72/A72LALH</p>	<p>78.3kW (28HP)</p>  <p>AJ*252LALHH UNIT : AJ*108/A72/A72LALH</p>	<p>84.8kW (30HP)</p>  <p>AJ*270LALHH UNIT : AJ*126/A72/A72LALH</p>
<p>113.5kW (40HP)</p>  <p>AJ*360LALHH UNIT : AJ*126/126/108LALH</p>	<p>120.0kW (42HP)</p>  <p>AJ*378LALHH UNIT : AJ*126/126/126LALH</p>	<p>125.0kW (44HP)</p>  <p>AJ*396LALHH UNIT : AJ*144/126/126LALH</p>



AJ* : AJY(FUJITSU), AJH(GENERAL)

Specifications

Space saving combination

Rating Capacity range		HP	8	10	12	14	16	18	20	22	24		
													
Model name			AJ*A72LALH	AJ*A90LALH	AJ*108LALH	AJ*126LALH	AJ*144LALH	AJ*162LALH	AJ*180LALH	AJ*198LALH	AJ*216LALH		
Unit 1 Unit 2 Unit 3			AJ*A72LALH	AJ*A90LALH	AJ*108LALH	AJ*126LALH	AJ*144LALH	AJ*A90LALH AJ*A72LALH	AJ*108LALH AJ*A72LALH	AJ*108LALH AJ*A90LALH	AJ*108LALH AJ*108LALH		
Maximum Connectable Indoor Unit*1			15	16	17	21	24	32	32	32	35		
Indoor unit connectable capacity		Cooling	kW		11.2-33.6	14.0-42.0	16.8-50.2	20.0-60.0	22.4-67.2	25.2-75.6	28.0-83.9	30.8-92.3	33.5-100.5
Power source		3-phase 4 wire, 400 V, 50Hz											
Capacity		Cooling	kW		22.4	28.0	33.5	40.0	45.0	50.4	55.9	61.5	67.0
		Heating	kW		25.0	31.5	37.5	45.0	50.0	56.5	62.5	69.0	75.0
Input power		Cooling	kW		5.51	7.73	9.62	11.53	14.17	13.24	15.13	17.35	19.24
		Heating	kW		5.72	7.83	9.28	11.45	12.60	13.55	15.00	17.11	18.56
EER		Cooling	W/W		4.07	3.62	3.48	3.47	3.18	3.81	3.69	3.54	3.48
COP		Heating	W/W		4.37	4.02	4.04	3.93	3.97	4.17	4.17	4.03	4.04
Air flow rate		High	m ³ /h		11,100	11,100	11,100	13,000	13,000	11,100 x 2	11,100 x 2	11,100 x 2	11,100 x 2
Sound pressure level*2		Cooling	dB		56	58	58	60	61	60	60	61	61
		Heating	(A)		58	59	60	61	61	62	62	63	63
Maximum external static pressure		Pa		80	80	80	80	80	80	80	80	80	
Compressor motor output		kW		3.9	3.9	3.9 + 4.5	3.9 + 4.5	3.9 + 4.5	3.9 x 2	3.9 x 2 + 4.5	3.9 x 2 + 4.5	3.9 x 2 + 4.5 x 2	
Heat exchanger fin		Blue fin											
Dimensions		Height	mm		1,690	1,690	1,690	1,690	1,690	1,690	1,690	1,690	1,690
		Width	mm		930	930	930	1,240	1,240	930 x 2	930 x 2	930 x 2	930 x 2
		Depth	mm		765	765	765	765	765	765	765	765	765
Weight		kg		220	220	275	296	296	220 + 220	275 + 220	275 + 220	275 + 220	275 + 275
Refrigerant charge		kg		11.2	11.2	11.8	11.8	11.8	11.2 x 2	11.8 + 11.2	11.8 + 11.2	11.8 x 2	
Connection pipe diameter		Liquid	mm		12.70	12.70	12.70	12.70	12.70	15.88	15.88	15.88	15.88
		Gas	mm		22.20	22.20	28.58	28.58	28.58	28.58	28.58	34.92	34.92
Operation range		Cooling	°C		-15 to 46	-15 to 46	-15 to 46	-15 to 46	-15 to 46	-5 to 46	-5 to 46	-5 to 46	-5 to 46
		Heating	°C		-20 to 21	-20 to 21	-20 to 21	-20 to 21	-20 to 21	-20 to 21	-20 to 21	-20 to 21	-20 to 21

Energy efficiency combination

Rating Capacity range		HP	16	22	24	26	28	30		
										
Model name			AJ*144LALHH	AJ*198LALHH	AJ*216LALHH	AJ*234LALHH	AJ*252LALHH	AJ*270LALHH		
Unit 1 Unit 2 Unit 3			AJ*A72LALH AJ*A72LALH	AJ*126LALH AJ*A72LALH	AJ*A72LALH AJ*A72LALH AJ*A72LALH	AJ*A90LALH AJ*A72LALH AJ*A72LALH	AJ*108LALH AJ*A72LALH AJ*A72LALH	AJ*126LALH AJ*A72LALH AJ*A72LALH		
Maximum Connectable Indoor Unit*1			30	33	36	39	42	45		
Indoor unit connectable capacity		Cooling	kW		22.4-67.2	31.2-93.6	33.6-100.8	36.4-109.2	39.2-117.4	42.4-127.2
Power source		3-phase 4 wire, 400 V, 50Hz								
Capacity		Cooling	kW		44.8	62.4	67.2	72.8	78.3	84.8
		Heating	kW		50.0	70.0	75.0	81.5	87.5	95.0
Input power		Cooling	kW		11.02	17.04	16.53	18.75	20.64	22.55
		Heating	kW		11.44	17.17	17.16	19.27	20.72	22.89
EER		Cooling	W/W		4.07	3.66	4.07	3.88	3.79	3.76
COP		Heating	W/W		4.37	4.08	4.37	4.23	4.22	4.15
Air flow rate		High	m ³ /h		11,100 x 2	13,000 + 11,100	11,100 x 3	11,100 x 3	11,100 x 3	13,000 + 11,000 x 2
Sound pressure level*2		Cooling	dB		59	61	61	62	62	63
		Heating	(A)		59	62	61	62	63	63
Maximum external static pressure		Pa		80	80	80	80	80	80	
Compressor motor output		kW		3.9 x 2	3.9 x 2 + 4.5	3.9 x 3	3.9 x 3	3.9 x 3 + 4.5	3.9 x 3 + 4.5	
Heat exchanger fin		Blue fin								
Dimensions		Height	mm		1,690	1,690	1,690	1,690	1,690	1,690
		Width	mm		930 x 2	930 + 1,240	930 x 3	930 x 3	930 x 3	930 x 2 + 1,240
		Depth	mm		765	765	765	765	765	765
Weight		kg		220 + 220	296 + 220	220 + 220 + 220	220 + 220 + 220	275 + 220 + 220	296 + 220 + 220	
Refrigerant charge		kg		11.2 x 2	11.8 + 11.2	11.2 x 3	11.2 x 3	11.8 + 11.2 x 2	11.8 + 11.2 x 2	
Connection pipe diameter		Liquid	mm		12.70	15.88	15.88	15.88	15.88	19.05
		Gas	mm		28.58	34.92	34.92	34.92	34.92	34.92
Operation range		Cooling	°C		-5 to 46	-5 to 46	-5 to 46	-5 to 46	-5 to 46	-5 to 46
		Heating	°C		-20 to 21	-20 to 21	-20 to 21	-20 to 21	-20 to 21	-20 to 21







AJ* : AJY(FUJITSU), AJH(GENERAL)







Note : Specifications are based on the following conditions.

Cooling : Indoor temperature of 27°CDB / 19°CWB, and outdoor temperature of 35°CDB / 24°CWB.
Heating : Indoor temperature of 20°CDB / (15°CWB), and outdoor temperature of 7°CDB / 6°CWB.

Pipe length : 7.5 m; Height difference between outdoor unit and indoor unit : 0 m.

When cooling operation will be conducted at outdoor air temperature below -5°C, the outdoor unit must be installed in a position that is higher than or equal to those of indoor units.

26	28	30	32	34	36	38	40	42	44	46	48
											
AJ*234LALH	AJ*252LALH	AJ*270LALH	AJ*288LALH	AJ*306LALH	AJ*324LALH	AJ*342LALH	AJ*360LALH	AJ*378LALH	AJ*396LALH	AJ*414LALH	AJ*432LALH
AJ*126LALH AJ*108LALH	AJ*144LALH AJ*108LALH	AJ*144LALH AJ*126LALH	AJ*144LALH AJ*144LALH	AJ*108LALH AJ*108LALH AJ*A90LALH	AJ*108LALH AJ*108LALH AJ*108LALH	AJ*126LALH AJ*108LALH AJ*108LALH	AJ*144LALH AJ*108LALH AJ*108LALH	AJ*144LALH AJ*126LALH AJ*108LALH	AJ*144LALH AJ*144LALH AJ*108LALH	AJ*144LALH AJ*144LALH AJ*126LALH	AJ*144LALH AJ*144LALH AJ*144LALH
39	42	45	48	48	48	48	48	48	48	48	48
36.8-110.3	39.3-117.8	42.5-127.5	45.0-135.0	47.5-142.5	50.3-150.8	53.5-160.5	56.0-168.0	59.3-177.8	61.8-185.3	65.0-195.0	67.5-202.5
3-phase 4 wire, 400 V, 50Hz											
73.5	78.5	85.0	90.0	95.0	100.5	107.0	112.0	118.5	123.5	130.0	135.0
82.5	87.5	95.0	100.0	106.5	112.5	120.0	125.0	132.5	137.5	145.0	150.0
21.15	23.79	25.70	28.34	26.97	28.86	30.77	33.41	35.32	37.96	39.87	42.51
20.73	21.88	24.05	25.20	26.39	27.84	30.01	31.16	33.33	34.48	36.65	37.80
3.48	3.30	3.31	3.18	3.52	3.48	3.48	3.35	3.36	3.25	3.26	3.18
3.98	4.00	3.95	3.97	4.04	4.04	4.00	4.01	3.98	3.99	3.96	3.97
13,000 + 11,100	13,000 + 11,100	13,000 x 2	13,000 x 2	11,100 x 3	11,100 x 3	13,000 + 11,100 x 2	13,000 + 11,100 x 2	13,000 x 2 + 11,100	13,000 x 2 + 11,100	13,000 x 3	13,000 x 3
62	63	64	64	63	63	64	64	65	65	65	66
64	64	64	64	64	65	65	65	65	65	66	66
80	80	80	80	80	80	80	80	80	80	80	80
3.9 x 2 + 4.5 x 2	3.9 x 2 + 4.5 x 2	3.9 x 2 + 4.5 x 2	3.9 x 2 + 4.5 x 2	3.9 x 3 + 4.5 x 2	3.9 x 3 + 4.5 x 3	3.9 x 3 + 4.5 x 3	3.9 x 3 + 4.5 x 3	3.9 x 3 + 4.5 x 3	3.9 x 3 + 4.5 x 3	3.9 x 3 + 4.5 x 3	3.9 x 3 + 4.5 x 3
Blue fin	Blue fin	Blue fin	Blue fin	Blue fin	Blue fin	Blue fin	Blue fin	Blue fin	Blue fin	Blue fin	Blue fin
1,690	1,690	1,690	1,690	1,690	1,690	1,690	1,690	1,690	1,690	1,690	1,690
930 + 1,240	930 + 1,240	1,240 x 2	1,240 x 2	930 x 3	930 x 3	930 x 2 + 1,240	930 x 2 + 1,240	930 + 1,240 x 2	930 + 1,240 x 2	1,240 x 3	1,240 x 3
765	765	765	765	765	765	765	765	765	765	765	765
296 + 275	296 + 275	296 + 296	296 + 296	275 + 275 + 220	275 + 275 + 275	296 + 275 + 275	296 + 275 + 275	296 + 296 + 275	296 + 296 + 275	296 + 296 + 296	296 + 296 + 296
11.8 x 2	11.8 x 2	11.8 x 2	11.8 x 2	11.8 x 2 + 11.2	11.8 x 3	11.8 x 3	11.8 x 3	11.8 x 3	11.8 x 3	11.8 x 3	11.8 x 3
15.88	15.88	19.05	19.05	19.05	19.05	19.05	19.05	19.05	19.05	19.05	19.05
34.92	34.92	34.92	34.92	34.92	41.27	41.27	41.27	41.27	41.27	41.27	41.27
-5 to 46	-5 to 46	-5 to 46	-5 to 46	-5 to 46	-5 to 46	-5 to 46	-5 to 46	-5 to 46	-5 to 46	-5 to 46	-5 to 46
-20 to 21	-20 to 21	-20 to 21	-20 to 21	-20 to 21	-20 to 21	-20 to 21	-20 to 21	-20 to 21	-20 to 21	-20 to 21	-20 to 21

32	34	36	40	42	44
					
AJ*288LALHH	AJ*306LALHH	AJ*324LALHH	AJ*360LALHH	AJ*378LALHH	AJ*396LALHH
AJ*108LALH AJ*108LALH AJ*A72LALH	AJ*126LALH AJ*108LALH AJ*A72LALH	AJ*126LALH AJ*126LALH AJ*A72LALH	AJ*126LALH AJ*126LALH AJ*108LALH	AJ*126LALH AJ*126LALH AJ*126LALH	AJ*144LALH AJ*126LALH AJ*126LALH
48	48	48	48	48	48
44.7-134.1	48.0-143.8	51.2-153.6	56.8-170.2	60.0-180.0	62.5-187.5
3-phase 4 wire, 400 V, 50Hz					
89.4	95.9	102.4	113.5	120.0	125.0
100.0	107.5	115.0	127.5	135.0	140.0
24.75	26.66	28.57	32.68	34.59	37.23
24.28	26.45	28.62	32.18	34.35	35.50
3.61	3.60	3.58	3.47	3.47	3.36
4.12	4.06	4.02	3.96	3.93	3.94
11,100 x 3	13,000 + 11,100 x 2	13,000 x 2 + 11,100	13,000 x 2 + 11,100	13,000 x 3	13,000 x 3
62	63	64	64	65	65
64	64	65	65	66	66
80	80	80	80	80	80
3.9 x 3 + 4.5 x 2	3.9 x 3 + 4.5 x 2	3.9 x 3 + 4.5 x 2	3.9 x 3 + 4.5 x 3	3.9 x 3 + 4.5 x 3	3.9 x 3 + 4.5 x 3
Blue fin	Blue fin	Blue fin	Blue fin	Blue fin	Blue fin
1,690	1,690	1,690	1,690	1,690	1,690
930 x 3	930 x 2 + 1,240	930 + 1,240 x 2	930 + 1,240 x 2	1,240 x 3	1,240 x 3
765	765	765	765	765	765
275 + 275 + 220	296 + 275 + 220	296 + 296 + 220	296 + 296 + 275	296 + 296 + 296	296 + 296 + 296
11.8 x 2 + 11.2	11.8 x 2 + 11.2	11.8 x 2 + 11.2	11.8 x 3	11.8 x 3	11.8 x 3
19.05	19.05	19.05	19.05	19.05	19.05
34.92	34.92	41.27	41.27	41.27	41.27
-5 to 46	-5 to 46	-5 to 46	-5 to 46	-5 to 46	-5 to 46
-20 to 21	-20 to 21	-20 to 21	-20 to 21	-20 to 21	-20 to 21

*1 Minimum connectable indoor unit number is 2.
However ARXC72 and ARXC90 can be used single connection.

*2 The noise value is the value when measured in an anechoic room.
When measured in the actual installed state, surrounding noise and reflections are received and the measured value is usually larger than the indicated value.

Dimensions

8, 10, 12HP

AJ*A72LALH / AJ*A90LALH / AJ*108LALH

(Unit : mm)

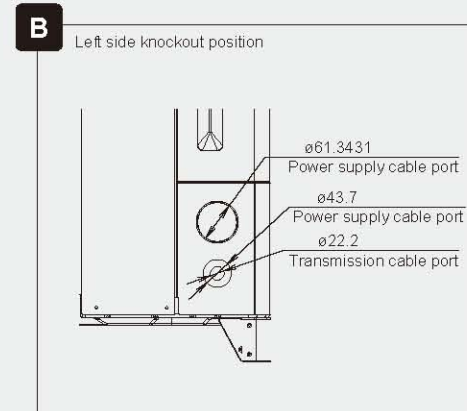
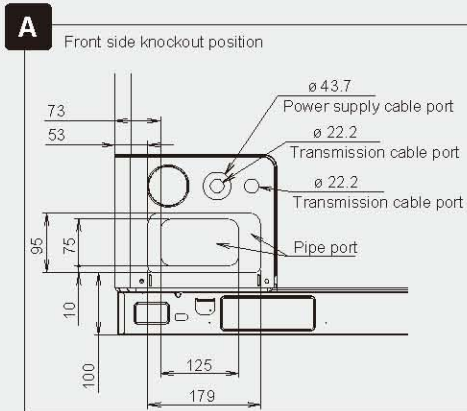
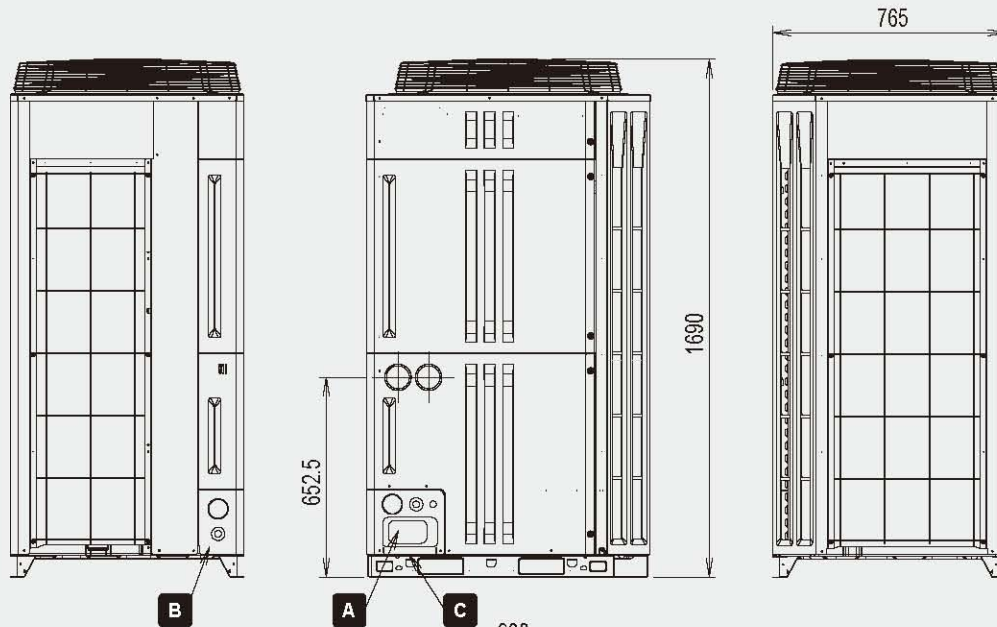
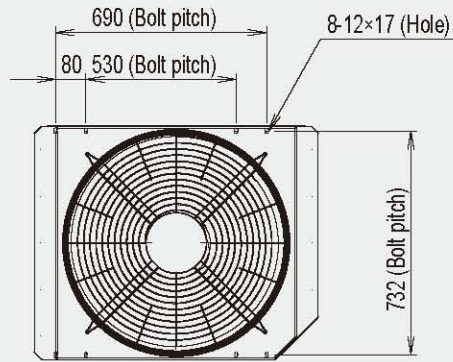

AJ* : AJY(FUJITSU), AJH(GENERAL)

14, 16HP





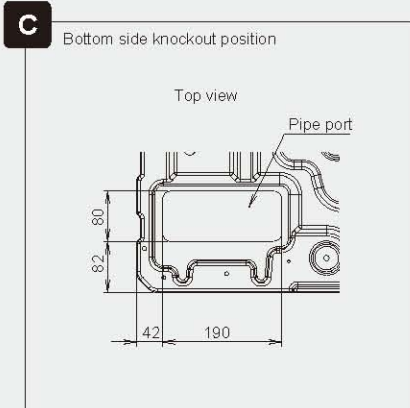
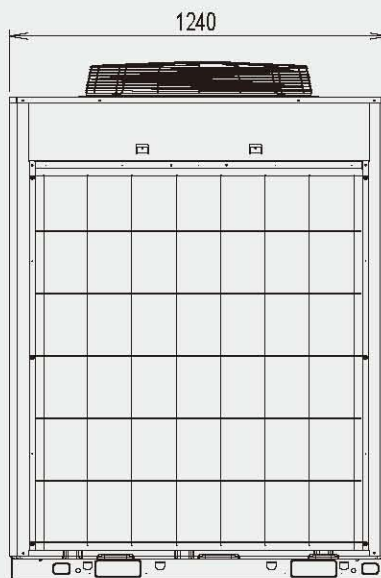
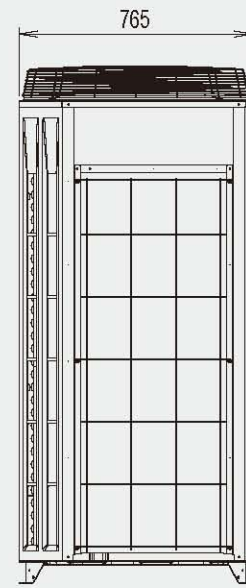
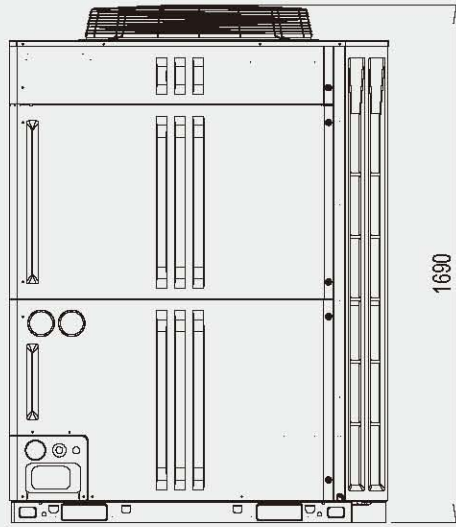
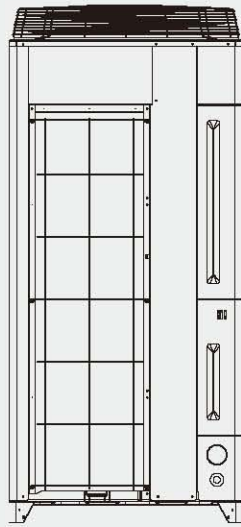
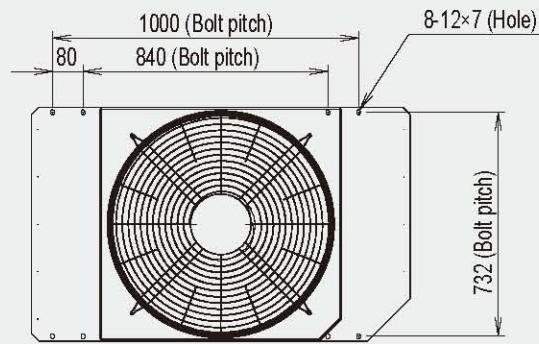























AJ*126LALH / AJ*144LALH

(Unit : mm)





























Indoor Unit Lineup

12 Types, 55 Models, Capacity range from 2.2kW to 25.0kW

Capacity range (kW)	2.2	2.8	3.6	4.5	5.6
Model code	7	9	12	14	18
Compact Cassette	 AUXB07LALH	 AUXB09LALH	 AUXB12LALH	 AUXB14LALH	 AUXB18LALH
Cassette					 AUXD18LALH
Compact Duct	 ARXB07LALH	 ARXB09LALH	 ARXB12LALH	 ARXB14LALH	 ARXB18LALH
Slim Duct NEW (Drain pump internal)	NEW  ARXD07LATH	NEW  ARXD09LATH	NEW  ARXD12LATH	NEW  ARXD14LATH	NEW  ARXD18LATH
Low Static Pressure Duct					
Duct					
High Static Pressure Duct					
Floor / Ceiling			NEW  AB*A12LBTH	NEW  AB*A14LBTH	NEW  AB*A18LBTH
Ceiling					
Compact Wall Mounted (EEV internal)	 AS*A07LACH	 AS*A09LACH	 AS*A12LACH	 AS*A14LACH	
Compact Wall Mounted (EEV external)	 AS*E07LACH	 AS*E09LACH	 AS*E12LACH	 AS*E14LACH	
	<small>With this model, connection of EV kit is necessary.</small>				
Wall Mounted					NEW  AS*A18LACH

AB* : ABY(FUJITSU), ABH(GENERAL) AS* : ASY(FUJITSU), ASH(GENERAL)

Comprehensive range of indoor units of variety design and capacity ranges available which can be selected to suit any air conditioning needs.

7.1 24	9.0 30	11.2 36	12.5 45	14.0 54	18.0 60	22.4 72	25.0 90
 AUXB24LALH							
 AUXD24LALH	 AUXA30LALH	 AUXA36LALH	 AUXA45LALH	 AUXA54LALH			
NEW  ARXD24LATH							
 ARXB24LATH	 ARXB30LATH	 ARXB36LATH	 ARXB45LATH				
 ARXA24LATH	 ARXA30LATH	 ARXA36LATH	 ARXA45LATH				
		 ARXC36LATH	 ARXC45LATH		 ARXC60LATH	 ARXC72LATH	 ARXC90LATH
NEW  AB*A24LBTH							
	NEW  AB*A30LBTH	NEW  AB*A36LBTH	NEW  AB*A45LBTH	NEW  AB*A54LBTH			
NEW  AS*A24LACH	NEW  AS*A30LACH						

Compact Cassette

Models

- AUXB07LALH
- AUXB09LALH
- AUXB12LALH
- AUXB14LALH
- AUXB18LALH
- AUXB24LALH



Compact size panel design that fits standard ceiling panel (600x600mm)

2-stage turbo fan

High efficiency design by 2 stage structure

An evenly spread air distribution across the heat exchanger is possible due to the new 2 stage turbo fan which produces two separate airflow streams.

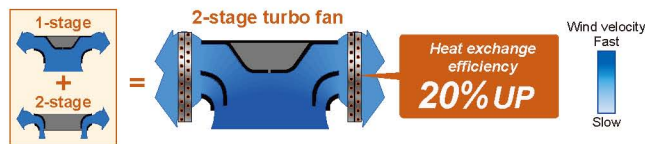

Previous turbo fan

In the case of a previous fan, the air outlet range was narrow as the airflow moved to the motor side which meant the velocity of air passing through the heat exchanger was uneven.



Quiet quality

Optimization of wing form (laminar wing type) and wing number (7 blades each)

Designed by CFD-analysis (fluid) simulations

Adoption of laminar wing

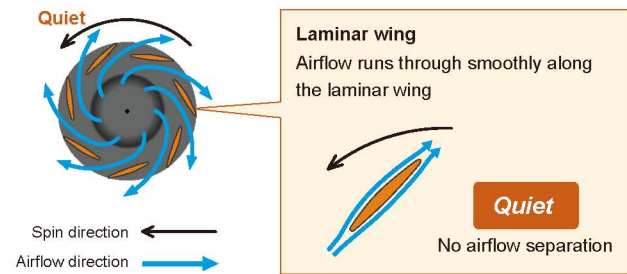

Specifications

Model name			AUXB07LALH	AUXB09LALH	AUXB12LALH	AUXB14LALH	AUXB18LALH	AUXB24LALH
Power source			230V ~, 50Hz					
Capacity	Cooling	kW	2.2	2.8	3.6	4.5	5.6	7.1
	Heating		2.8	3.2	4.1	5.0	6.3	8.0
Input power		W	25	25	29	35	36	84
Airflow rate	High	m³/h	540	550	600	680	710	1,030
	Med		450	450	530	590	580	830
	Low		350	350	390	390	400	450
Sound pressure level	High	dB(A)	34	35	37	38	41	50
	Med		30	30	34	34	35	44
	Low		25	25	27	27	27	30
Dimensions (H x W x D)		mm	245 x 570 x 570					
Weight		kg	15				17	
Connection pipe diameter	Liquid (Flare)	mm	ø6.35				ø9.52	
	Gas (Flare)		ø12.70				ø15.88	
	Drain		ø25 (I.D.) ; ø32 (O.D.)					
Grille(option)	Model name		UTG-UF*C-W					
	Dimensions (H x W x D)		50 x 700 x 700					
	Weight		2.6					

F* : FY (FUJITSU) ; FG (GENERAL)

Note : Specifications are based on the following conditions.

Cooling : Indoor temperature of 27°CDB / 19°CWB, and outdoor temperature of 35°CDB / 24°CWB.

Heating : Indoor temperature of 20°CDB / (15°CWB), and outdoor temperature of 7°CDB / 6°CWB.

Pipe length : 7.5 m; Height difference between outdoor unit and indoor unit : 0 m. Voltage : 230 [V].

Improvement of the airflow distribution

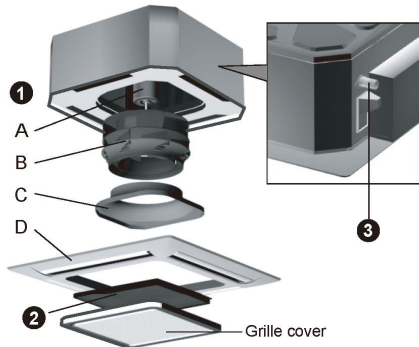

① Maintenance of fan motor and fan

Maintenance of the fan motor and fan can be done easily after taking off the panel as the bell mouth of the fan can be removed easily.

A : Fan motor B : 2-stage turbo fan
C : Bell-mouth D : Panel

② Long life filter : standard equipment

③ Adaptation of transparent drainage parts

During installation, maintenance and operation, the drain pump and kit can be checked easily.

High lift drain pump

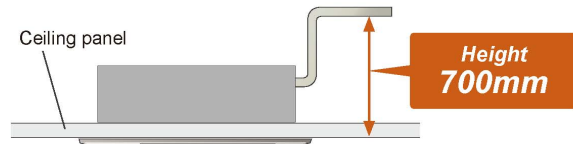

High ceiling mode

The compact cassette can be installed up to a height of 3.0m (12/14/18/24).

Model code	The maximum height from floor to ceiling (m)	
	Standard mode	High ceiling mode
07	2.7	—
09	2.7	—
12	2.7	3.0
14	2.7	3.0
18	2.7	3.0
24	2.7	3.0

Compact design

World's first 24,000Btu model in the compact cassette category (Easy installation by taking off ceiling panel of 600 x 600 size)



Optional parts

Air Outlet Shutter Plate : UTR-YDZB
Insulation Kit for High Humidity : UTZ-KXGC
Fresh Air Intake Kit : UTZ-VXAA

Dimensions (Unit : mm)

Models: AUXB07 / AUXB09 / AUXB12 / AUXB14 / AUXB18 / AUXB24

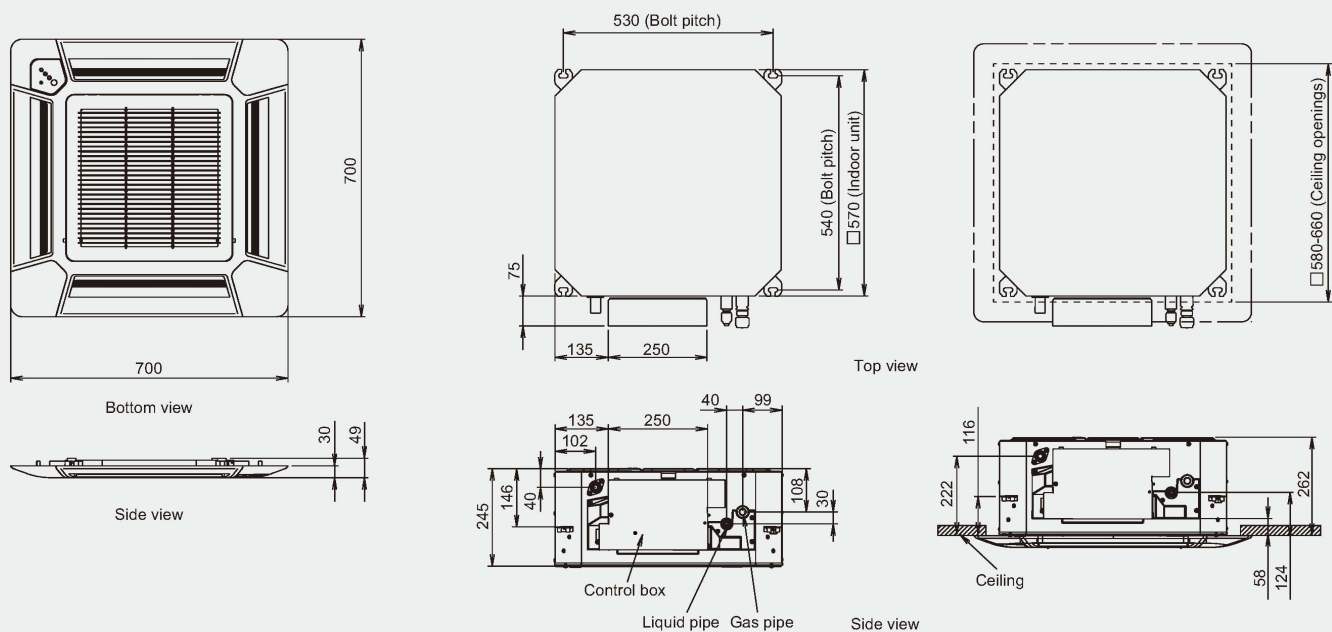

Cassette

Models

- AUXD18LALH
- AUXD24LALH
- AUXA30LALH
- AUXA36LALH
- AUXA45LALH
- AUXA54LALH



Powerful, wide airflow and quiet operation

High efficiency turbo fan with 3-dimensional blade

High efficiency airflow distribution has been achieved by the introduction of a 3 dimensional blade which increases the air passing over the heat exchanger.

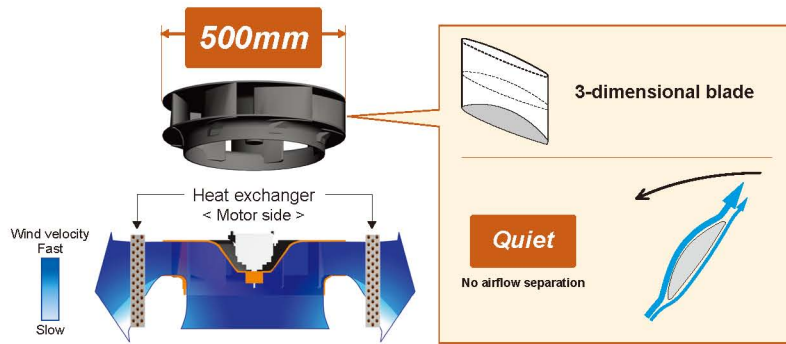

Previous turbo fan

Air passing through the heat exchanger was uneven and the air would only flow close to the ceiling.

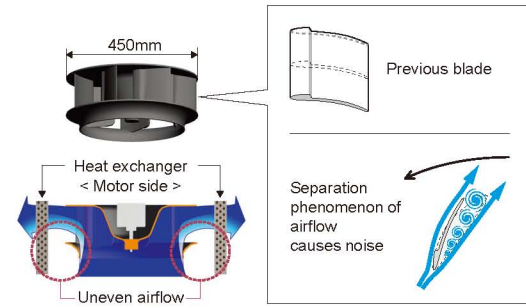

← : Spin direction → : Airflow direction ●●●● : Turbulent flow noise

Specifications

Model name			AUXD18LALH	AUXD24LALH	AUXA30LALH	AUXA36LALH	AUXA45LALH	AUXA54LALH
Power source			230V ~, 50Hz					
Capacity	Cooling	kW	5.6	7.1	9.0	11.2	12.5	14.0
	Heating		6.3	8.0	10.0	12.5	14.0	16.0
Input power		W	39	46	59	80	99	119
Airflow rate	High	m³/h	1,150	1,280	1,600	1,800	1,900	2,000
	Med		940	1,040	1,300	1,300	1,370	1,370
	Low		870	870	1,100	1,100	1,100	1,100
Sound pressure level	High	dB(A)	36	38	40	44	46	47
	Med		30	33	38	38	39	39
	Low		29	29	33	33	33	33
Dimensions (H x W x D)		mm	246 x 840 x 840			288 x 840 x 840		
Weight		kg	23			27		
Connection pipe diameter	Liquid (Flare)	mm	ø9.52					
	Gas (Flare)		ø15.88			ø19.05		
	Drain		ø25 (I.D.) ; ø32 (O.D.)					
Grille(option)	Model name		UTG-UG*A-W					
	Dimensions (H x W x D)		50 x 950 x 950					
	Weight		5.5					

G* : GY(FUJITSU) ; GG(GENERAL)

Note : Specifications are based on the following conditions.

Cooling : Indoor temperature of 27°CDB / 19°CWB, and outdoor temperature of 35°CDB / 24°CWB.

Heating : Indoor temperature of 20°CDB / (15°CWB), and outdoor temperature of 7°CDB / 6°CWB.

Pipe length : 7.5 m; Height difference between outdoor unit and indoor unit : 0 m. Voltage : 230 [V].

Improvement of the airflow distribution

The louvre design distributes air leaving a space between the chassis and the ceiling allowing for and wide air flow distribution.

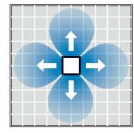
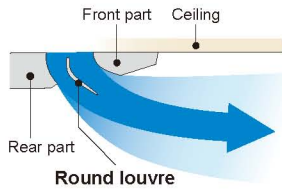

Much less temperature irregularity happens by spreading airflow widely

High lift drain pump

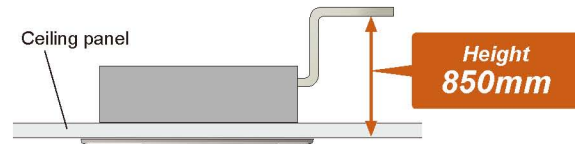

High ceiling mode

This cassette can be installed up to a height of 4.2m (36/45/54).

Model code	The maximum height from floor to ceiling (m)	
	Standard mode	High ceiling mode
18	3.0	3.5
24	3.0	3.5
30	3.2	3.6
36	3.2	4.2
45	3.2	4.2
54	3.2	4.2

Adjustment of hanger position is possible after installation

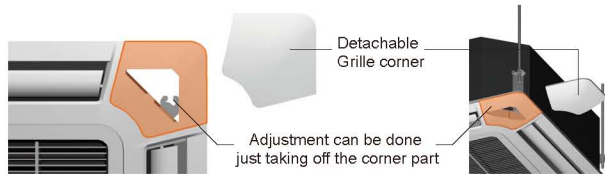

One way aperture installation

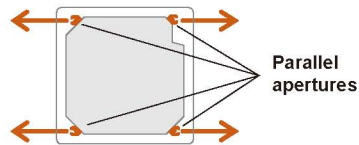

Optional parts

IR Receiver Kit :	UTY-LRH*B1
Air Outlet Shutter Plate :	UTR-YDZC
Panel Spacer :	UTG-BGYA-W
Insulation Kit for High Humidity :	UTZ-KXGA / UTZ-KXGB
Wide Panel :	UTG-AGYA-W
Fresh Air Intake Kit :	UTZ-VXGA

H*: HY(FUJITSU), HG(GENERAL)

Dimensions (Unit: mm) () : AUXD18 / AUXD24

Models: AUXD18LALH / AUXD24LALH (Slim type)
AUXA30LALH / AUXA36LALH / AUXA45LALH / AUXA54LALH

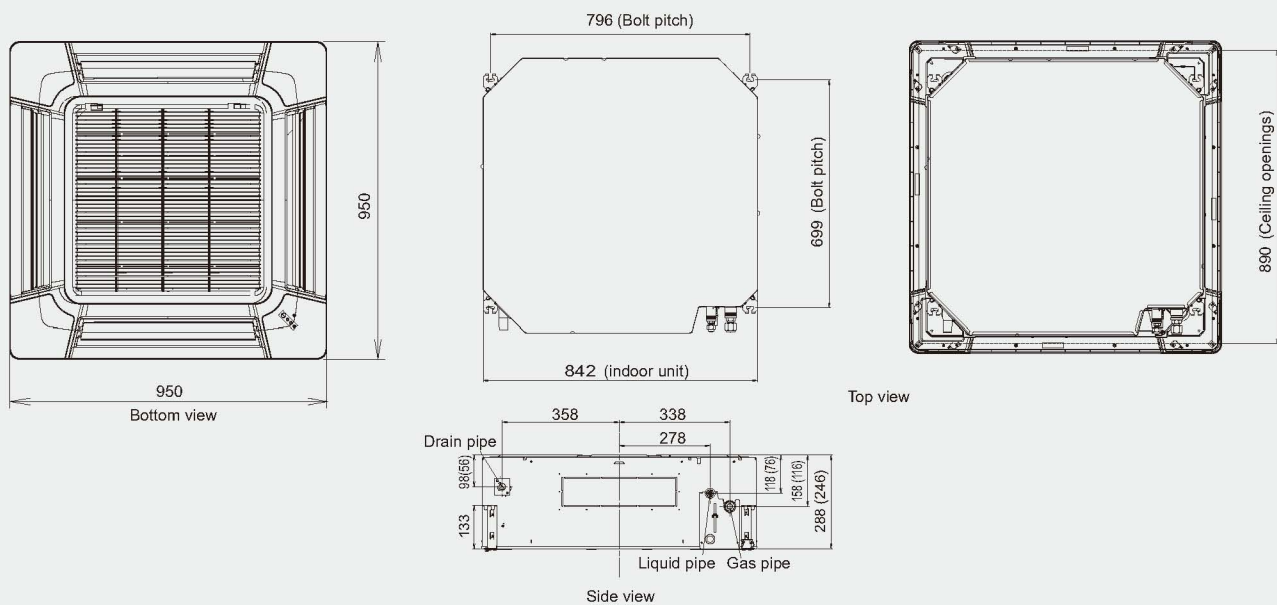

Compact Duct

Models

- ARXB07LALH
- ARXB09LALH
- ARXB12LALH
- ARXB14LALH
- ARXB18LALH



ARXB07LALH
ARXB09LALH



ARXB12LALH
ARXB14LALH
ARXB18LALH

Small and compact indoor unit suitable for many applications

Low noise level

A low noise level has been achieved for each capacity

Model		7	9	12	14	18
Static pressure range	Pa	0 to 50				
Noise level (Low speed)	dB(A)	24	27	25	30	30

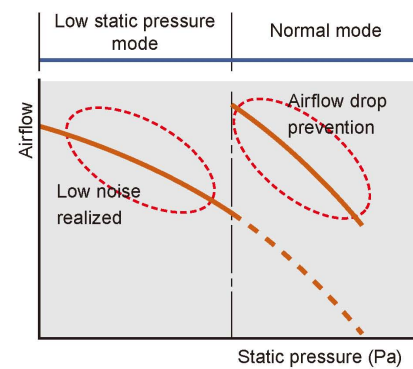

Specifications

Model name			ARXB07LALH	ARXB09LALH	ARXB12LALH	ARXB14LALH	ARXB18LALH	
Power source			230V ~, 50Hz					
Capacity	Cooling	kW	2.2	2.8	3.6	4.5	5.6	
	Heating		2.8	3.2	4.0	5.0	6.3	
Input power		W	46	55	63	90	96	
Airflow rate	High	m ³ /h	370	440	590	800	890	
	Med		310	370	500	750	810	
	Low		280	340	450	700	730	
Static pressure range		Pa	0 to 50					
Standard static pressure			25	25	25	25	25	
Sound pressure level	High	dB(A)	29	31	30	33	36	
	Med		26	29	28	32	34	
	Low		24	27	25	30	30	
Dimensions (H x W x D)		mm	217 x 663 x 595			217 x 953 x 595		
Weight		kg	18			25		
Connection pipe diameter	Liquid (Flare)	mm	ø6.35				ø9.52	
	Gas (Flare)		ø12.70				ø15.88	
	Drain		ø25 (I.D.) ; ø32 (O.D.)					

Note : Specifications are based on the following conditions.

Cooling : Indoor temperature of 27°CDB / 19°CWB, and outdoor temperature of 35°CDB / 24°CWB.
 Heating : Indoor temperature of 20°CDB / (15°CWB), and outdoor temperature of 7°CDB / 6°CWB.
 Pipe length : 7.5 m; Height difference between outdoor unit and indoor unit : 0 m.

Compact design

Ultra-slim duct air conditioner for easy installation

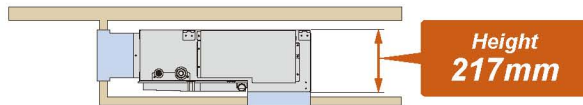

Slim size (217mm) allows installation even where the space behind the ceiling is narrow.

Two-direction drain piping

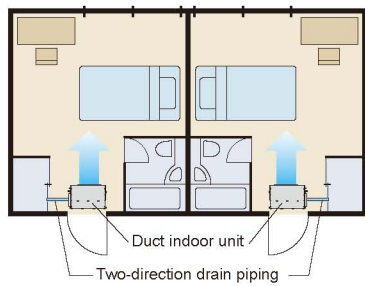

Air-intake

Air intake direction can be selected to match the installation site.

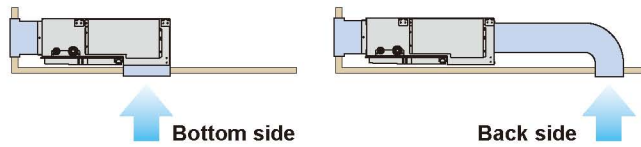

Flexible installation

Ceiling concealed

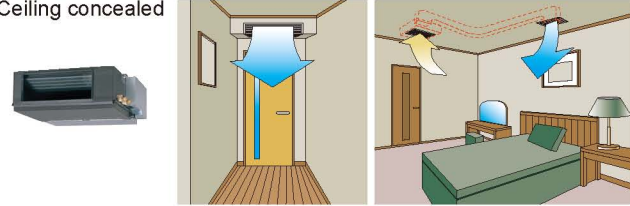

Floor concealed

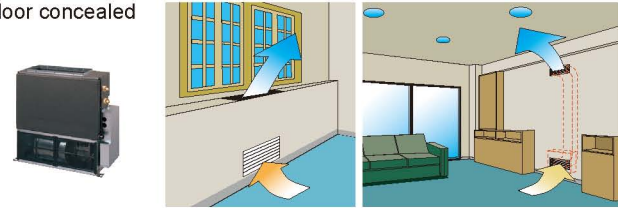

Filter (Accessory)

ARXB07 / ARXB09

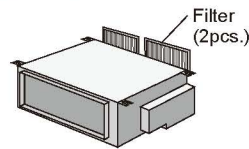

ARXB12 / ARXB14 / ARXB18

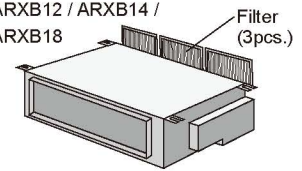

Optional parts

Remote Sensor Unit : UTD-RS100

IR Receiver Unit : UTB-*WC

Drain Pump Unit : UTZ-PX1BBA

*WC : YWC, TWC

Dimensions (Unit : mm) () : AR7 / AR9

Models: ARXB07 / ARXB09 / ARXB12 / ARXB14 / ARXB18

*Service accessibility must be allowed for when installing the product.
Please consult the installation manual for the necessary service access size.

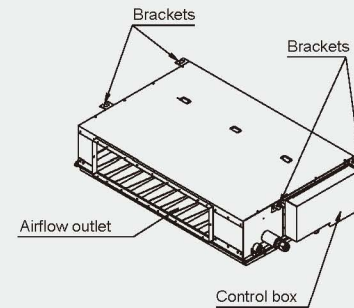
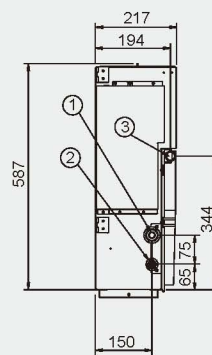
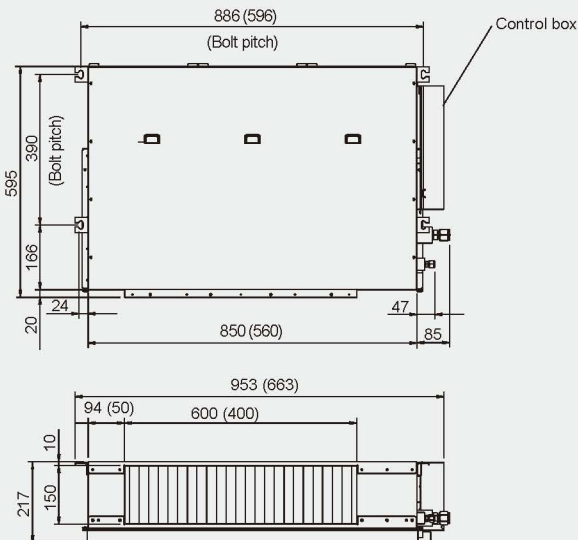

- ① Refrigerant piping flare connection (Gas)
- ② Refrigerant piping flare connection (Liquid)
- ③ Drain piping connection

Slim Duct

Models (Drain pump internal model)

- ARXD07LATH
- ARXD09LATH
- ARXD12LATH
- ARXD14LATH
- ARXD18LATH
- ARXD24LATH



ARXD07LATH ARXD12LATH
ARXD09LATH ARXD14LATH



ARXD18LATH



ARXD24LATH

Slim design and wide range of static pressure for flexible installation.

Slim design

This model is slim design, it can install at the place where a ceiling is narrow.

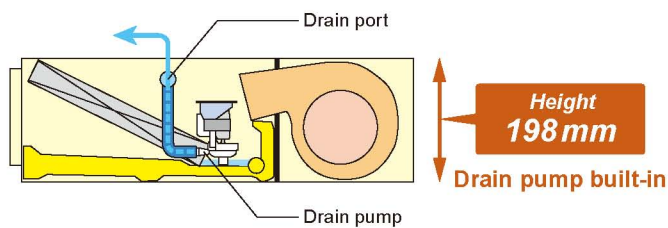

Flexible installation

Ceiling concealed

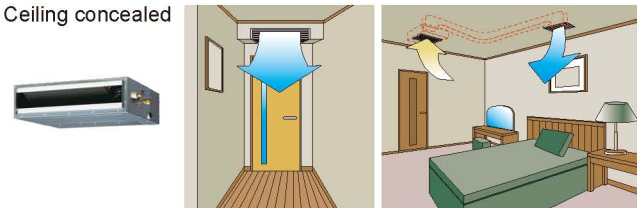

Floor concealed

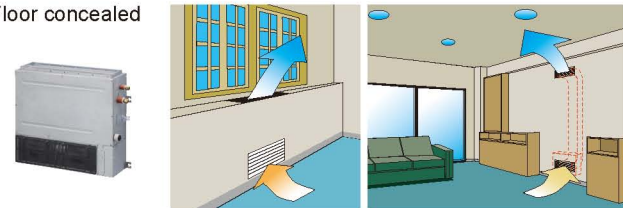

Specifications

Model name			ARXD07LATH	ARXD09LATH	ARXD12LATH	ARXD14LATH	ARXD18LATH	ARXD24LATH	
Power source			230V ~, 50Hz						
Capacity	Cooling	kW	2.2	2.8	3.6	4.5	5.6	7.1	
	Heating		2.8	3.2	4.0	5.0	6.3	8.0	
Input power		W	44	50	54	92	83	122	
Airflow rate	High	m³/h	550	600	600	800	940	1,330	
	Med		490	550	510	710	840	1,240	
	Low		440	480	450	610	750	1,100	
Static pressure range		Pa	0 to 90	0 to 90	0 to 90	0 to 90	0 to 90	0 to 50	
Standard static pressure			25	25	25	25	25	25	
Sound pressure level	High	dB(A)	28	29	30	34	34	35	
	Med		25	26	27	32	32	32	
	Low		22	24	24	28	28	29	
Dimensions (H x W x D)		mm	198 x 700 x 620				198 x 900 x 620	198 x 1,100 x 620	
Weight		kg	18		19		23	27	
Connection pipe diameter	Liquid (Flare)	mm	ø6.35				ø9.52		
	Gas (Flare)		ø12.70				ø15.88		
	Drain		ø22 (I.D.) ; ø26 (O.D.) : VP20						

Note : Specifications are based on the following conditions.

Cooling : Indoor temperature of 27°CDB / 19°CWB, and outdoor temperature of 35°CDB / 24°CWB.
 Heating : Indoor temperature of 20°CDB / (15°CWB), and outdoor temperature of 7°CDB / 6°CWB.
 Pipe length : 7.5 m; Height difference between outdoor unit and indoor unit : 0 m.

High lift drain pump

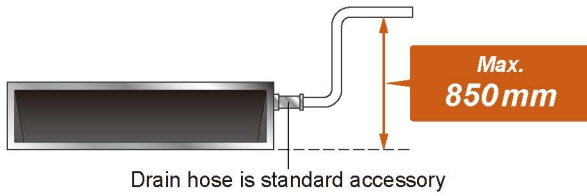

Selectable with a wide range of static pressure

By using DC fan motor, it is possible to change of static pressure range 0 to 90Pa. The change of static pressure range is possible by remote controller.



Static pressure range
0 to 90 Pa

*24 model is 0 to 50Pa

Auto Louver Grille Kit (Option)

Simple flat Auto Louver will provide comfort airflow and harmonize with luxury interior.

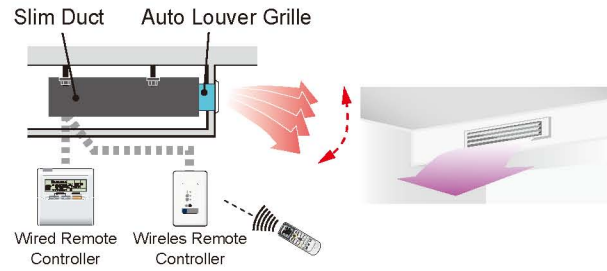

Filter (Accessory)

ARXD07 / 09 / 12 / 14 / 18

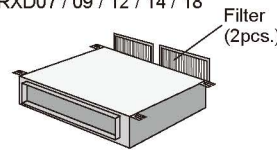

ARXD24

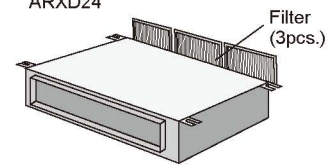

Air-intake

Air intake direction can be selected to match the installation site.

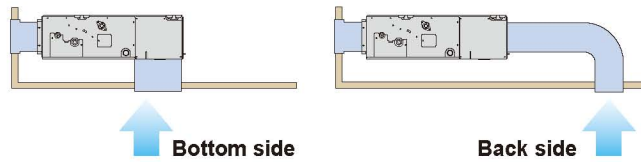

Optional parts

Remote Sensor Unit : UTD-RS100

IR Receiver Unit : UTB-*WC

Auto Louver Grille Kit : UTD-GXSA-W (for ARXD07/09/12/14LATH)
UTD-GXSB-W (for ARXD18LATH)
UTD-GXSC-W (for ARXD24LATH)

*WC : YWC, TWC

Dimensions (Unit : mm)

Models: ARXD07LATH / ARXD09LATH / ARXD12LATH / ARXD14LATH / ARXD18LATH / ARXD24LATH

*Service accessibility must be allowed for when installing the product.
Please consult the installation manual for the necessary service access size.

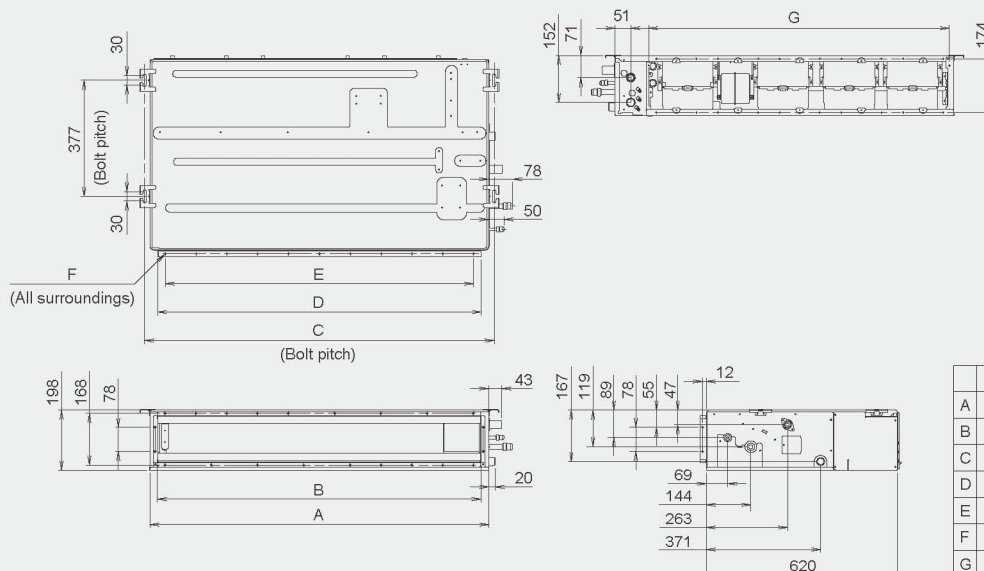

	ARXD07-14LATH	ARXD18LATH	ARXD24LATH
A	700	900	1100
B	650	850	1050
C	734	934	1134
D	650	850	1050
E	P100x6=600	P100x8=800	P100x10=1000
F	18xØ5	22xØ5	26xØ5
G	574	774	974

Low Static Pressure Duct / Duct

Models [Low Static Pressure Duct]

- ARXB24LATH**
- ARXB30LATH**
- ARXB36LATH**
- ARXB45LATH**



Indoor units suitable for quiet rooms such as a hotel or a bedroom

Models [Duct]

- ARXA24LATH**
- ARXA30LATH**
- ARXA36LATH**
- ARXA45LATH**

Slim Compact design allows for easy installation in narrow ceiling spaces up to 270mm

Slim & Compact design

In the case of bottom return air connection, not only does the indoor unit design allow for installation in a narrow ceiling space of up to 270mm, Further space savings have been achieved by mounting the electrical control box internally inside the chassis.

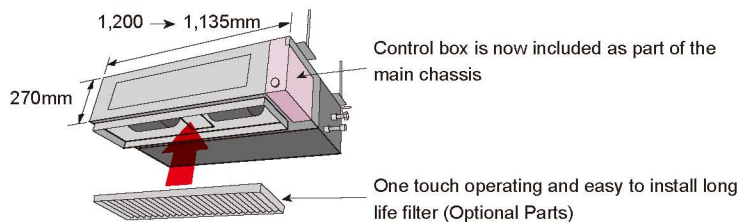

Specifications

Model name			ARXB24LATH	ARXB30LATH	ARXB36LATH	ARXB45LATH	ARXA24LATH	ARXA30LATH	ARXA36LATH	ARXA45LATH
Power source			230V ~, 50Hz				230V ~, 50Hz			
Capacity	Cooling	kW	7.1	9.0	11.2	12.5	7.1	9.0	11.2	12.5
	Heating		8.0	10.0	12.5	14.0	8.0	10.0	12.5	14.0
Input power		W	145	198	253	338	190	188	312	312
Airflow rate	High	m³/h	1,100	1,410	1,710	1,970	1,280	1,280	1,720	1,720
	Med		920	1,280	1,600	1,790	1,210	1,210	1,670	1,670
	Low		810	1,150	1,470	1,670	1,130	1,130	1,600	1,600
Static pressure range		Pa	0 to 80	0 to 80	0 to 80	0 to 80	30 to 150	30 to 150	30 to 150	30 to 150
Standard static pressure			40	50	50	60	100	100	100	100
Sound pressure level	High	dB(A)	31	34	37	41	38	40	43	43
	Med		27	32	35	38	36	38	41	41
	Low		25	29	33	36	34	36	39	39
Dimensions (H x W x D)		mm	270 x 1,135 x 700				270 x 1,135 x 700			
Weight		kg	43	45			43	45		
Connection pipe diameter	Liquid (Flare)	mm	ø9.52				ø9.52			
	Gas (Flare)		ø15.88		ø19.05		ø15.88		ø19.05	
	Drain		ø25 (I.D.) ; ø32 (O.D.)				ø25 (I.D.) ; ø32 (O.D.)			

Note : Specifications are based on the following conditions.

Cooling : Indoor temperature of 27°CDB / 19°CWB, and outdoor temperature of 35°CDB / 24°CWB.
 Heating : Indoor temperature of 20°CDB / (15°CWB), and outdoor temperature of 7°CDB / 6°CWB.
 Pipe length : 7.5 m; Height difference between outdoor unit and indoor unit : 0 m.

Line-up of low-noise and high-power models, compatible with a wide range of static pressure

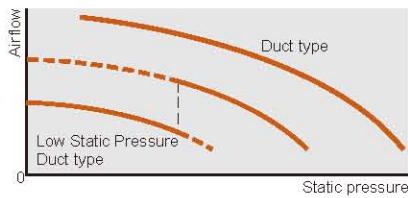

Low Static Pressure Duct type

Optimum model for hotels or bedrooms

An ultra low-noise model that achieves a quiet interior. Perfect for hotels or bedrooms with limited air duct installation space. Two different levels can be selected according to the static pressure range.

25dB

ARXB24
Low

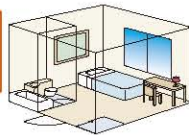

Duct type

Powerful model with a flexible design

With a powerful motor, appropriate for a wide range of static pressure. Flexible air duct installation is possible in a large space such as an office.

Max. 150Pa

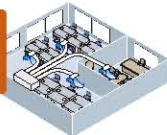

Two-direction drain piping

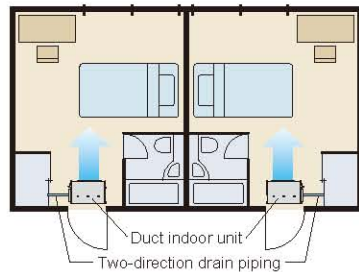

Easy maintenance

See below for the case of rear suction type

Previous model

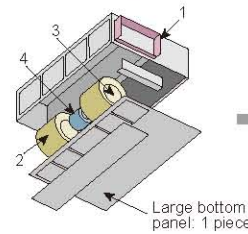

New model

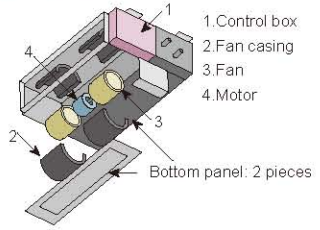

Structural improvement is attained by making the bottom panel two pieces, front and rear. The internal fan casing is also manufactured in two pieces, namely upper and lower. The maintenance of the motor and fan can be easily carried out by removing the rear panel and the lower part of the casing while leaving the main chassis installed.

Installation styles

Embedded in Ceiling

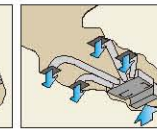
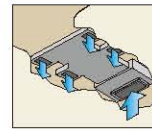

Hanging from Ceiling

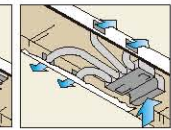
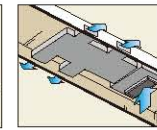

Optional parts

Remote Sensor Unit : UTD-RS100

Long Life Filter : UTD-LF25NA

Flange (Square) : UTD-SF045T

*WC : YWC, TWC

Flange (Round) : UTD-RF204

IR Receiver Unit : UTB-*WC

Drain Pump Unit : UTZ-PX1NBA

Dimensions (Unit : mm)

Models: ARXB24 / ARXB30 / ARXB36 / ARXB45
ARXA24 / ARXA30 / ARXA36 / ARXA45

*Service accessibility must be allowed for when installing the product.
Please consult the installation manual for the necessary service access size.

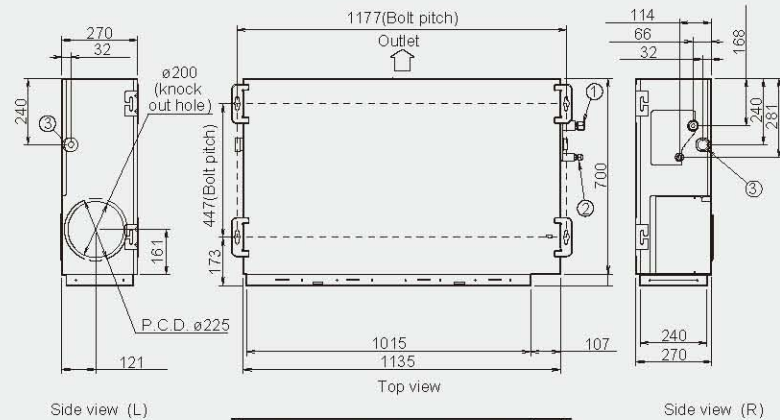
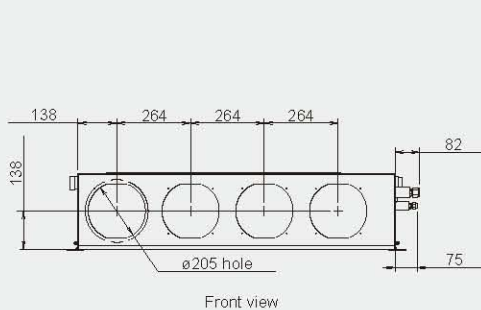

- ① Refrigerant piping flare connection (Liquid) :
- ② Refrigerant piping flare connection (Gas) :
- ③ Drain piping connection (Drain pipe)

High Static Pressure Duct

Models

- ARXC36LATH
- ARXC45LATH
- ARXC60LATH
- ARXC72LATH
- ARXC90LATH

These indoor units allow for high airflow quantities



ARXC36LATH
ARXC45LATH
ARXC60LATH



ARXC72LATH
ARXC90LATH

Specifications

Model name			ARXC36LATH	ARXC45LATH	ARXC60LATH	ARXC72LATH	ARXC90LATH
Power source			230V ~, 50Hz				
Capacity	Cooling	kW	11.2	12.5	18.0	22.4	25.0
	Heating		12.5	14.0	20.0	25.0	28.0
Input power	W		405	427	427	1,110	1,250
Airflow rate	High	m ³ /h	2,600	3,500	3,500	3,900	4,300
	Med		1,950	3,000	3,000	3,300	4,000
	Low		1,450	2,460	2,460	3,000	3,500
Static pressure range	Pa		100 to 200	100 to 250	100 to 250	50 to 300	100 to 300
Standard static pressure	Pa		100	100	100	260	250
Sound pressure level	High	dB(A)	45	49	49	51	53
	Med		38	45	45	48	51
	Low		32	42	42	45	49
Dimensions (H x W x D)	mm		400 x 1,050 x 500			450 x 1,550 x 700	
Weight	kg		45	47		82	85
Connection pipe diameter	Liquid	mm	ø9.52 (Flare)			ø12.70 (Brazing)	
	Gas		ø19.05 (Flare)			ø22.22 (Brazing)	
	Drain		ø25 (I.D.) ; ø32 (O.D.)				

Note : Specifications are based on the following conditions.

Cooling : Indoor temperature of 27°CDB / 19°CWB, and outdoor temperature of 35°CDB / 24°CWB.
 Heating : Indoor temperature of 20°CDB / (15°CWB), and outdoor temperature of 7°CDB / 6°CWB.
 Pipe length : 7.5 m; Height difference between outdoor unit and indoor unit : 0 m.

Easy installation (Compact size & Lightweight)

Models : ARXC36

A compact size and lightweight indoor unit has been developed by reducing the basic chassis and the overall material weight.

Volume
47.5%
down

Weight
40%
down

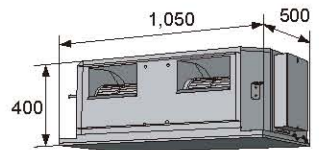

ARXC36LATH : 45kg (unit: mm)

Low noise

Models : ARXC36 / ARXC45 / ARXC60

Cutting off the corners of the conventional indoor unit front panel and fan casing, has enabled less turbulent air flow. Low noise is realized by adopting a plastic case and a plastic fan.

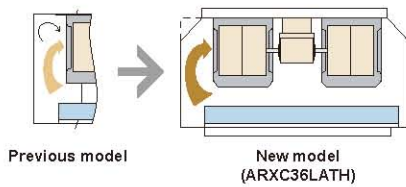

ARXC36LATH : Plastic fan [45dB(A)]

* Model : Material
(At 100Pa : Actual noise measurement value)

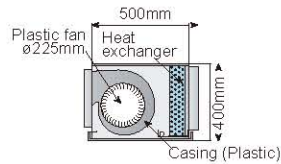

Static pressure selection

Models : ARXC72 / ARXC90

2 Types of static pressure mode are selectable.



Max.
300Pa

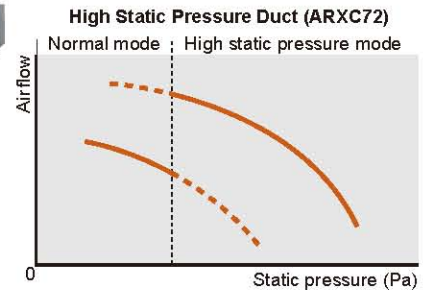

The adoption of a single phase fan motor allows
3 steps fan speed control

Optional parts

Long-Life Filter : UTD-LF60KA (For ARXC36 / 45 / 60)

IR Receiver Unit : UTB-*WC

Remote Sensor Unit : UTD-RS100

*WC : YWC, TWC

Dimensions (Unit : mm)

Models: ARXC36 / ARXC45 / ARXC60

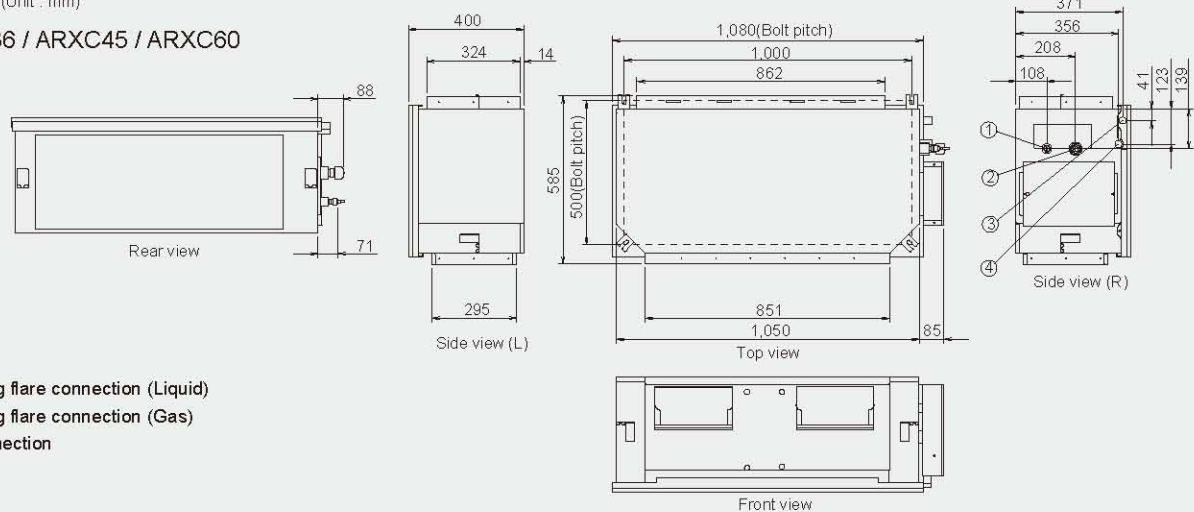

- ① Refrigerant piping flare connection (Liquid)
- ② Refrigerant piping flare connection (Gas)
- ③ Drain piping connection

Models: ARXC72 / ARXC90

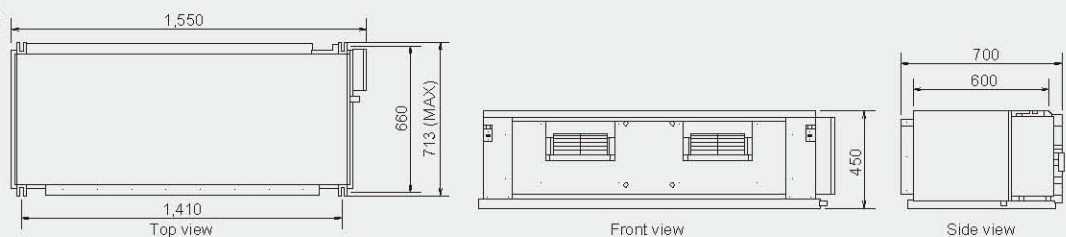

Floor / Ceiling

Models

- AB*A12LBTH**
- AB*A14LBTH**
- AB*A18LBTH**
- AB*A24LBTH**



The slim and lightweight design allow the unit to be suspended from the ceiling or installed on the floor. This type suits many room designs

Flexible installation

Example for floor installation

Floor console



Example for ceiling installation

Under ceiling



Specifications

Model name			AB*A12LBTH	AB*A14LBTH	AB*A18LBTH	AB*A24LBTH
Power source			230V ~, 50Hz			
Capacity	Cooling	kW	3.6	4.5	5.6	7.1
	Heating		4.0	5.0	6.3	8.0
Input power		W	30	42	74	99
Airflow rate	High	m ³ /h	660	780	1,000	1,000
	Med		570	640	720	820
	Low		490	550	580	680
Sound pressure level	High	dB(A)	36	40	46	47
	Med		32	36	39	42
	Low		28	34	35	37
Dimensions (H x W x D)		mm	199 x 990 x 655			
Weight		kg	25	27		
Connection pipe diameter	Liquid (Flare)	mm	ø6.35		ø9.52	
	Gas (Flare)		ø12.70		ø15.88	
	Drain		ø25 (I.D.) ; ø32 (O.D.)			

AB*: ABY(FUJITSU), ABH(GENERAL)

Note : Specifications are based on the following conditions.

Cooling : Indoor temperature of 27°CDB / 19°CWB, and outdoor temperature of 35°CDB / 24°CWB.

Heating : Indoor temperature of 20°CDB / (15°CWB), and outdoor temperature of 7°CDB / 6°CWB.

Pipe length : 7.5 m; Height difference between outdoor unit and indoor unit : 0 m.

Voltage : 230 [V].

Double auto swing

A combination of up/down and right/left directional swing allows three-dimensional air direction control.

RIGHT and LEFT SWING

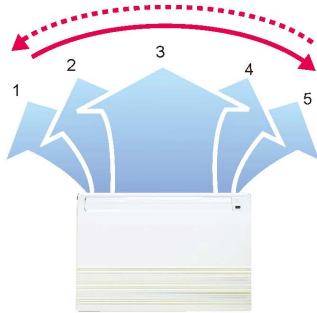

UP and DOWN SWING

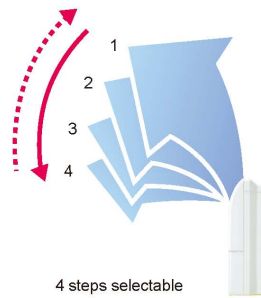

Super vane

Double Louvre Super vane with newly developed special configuration boosts airflow sending cool air quickly to every corner of the room.

Auto-closing louvre

When operation is stopped, the louvres will automatically close. (This function is available on all non-ducted models.)

Compact design

Symmetrical, slim and compact design.

High power DC fan motor

- High power
- Wide rotation range
- High efficiency

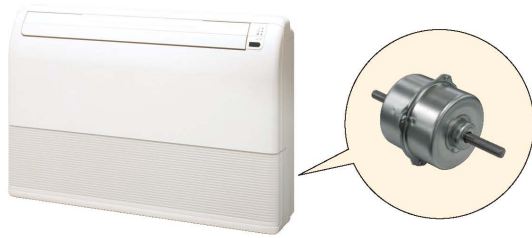

Dimensions (Unit : mm)

Models: AB*A12 / AB*A14 / AB*A18 / AB*A24

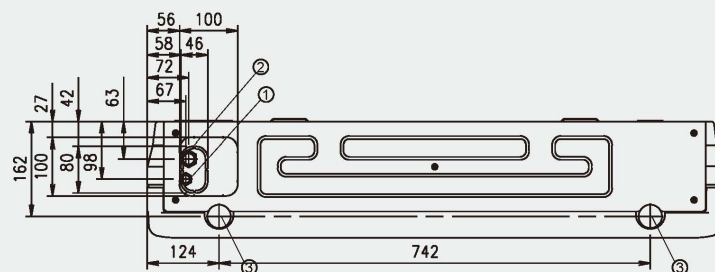
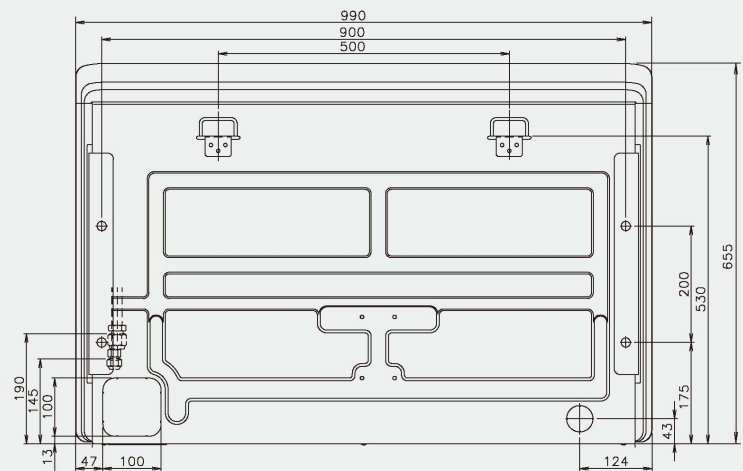
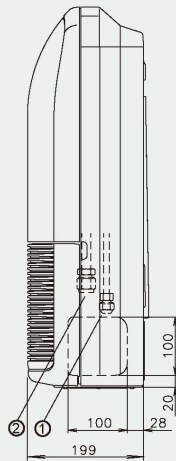

- ① Refrigerant piping flare connection (Liquid)
- ② Refrigerant piping flare connection (Gas)
- ③ Drain piping connection

Ceiling

Models

- AB*A30LBTH**
- AB*A36LBTH**
- AB*A45LBTH**
- AB*A54LBTH**



Easily concealed in any installation

Installation

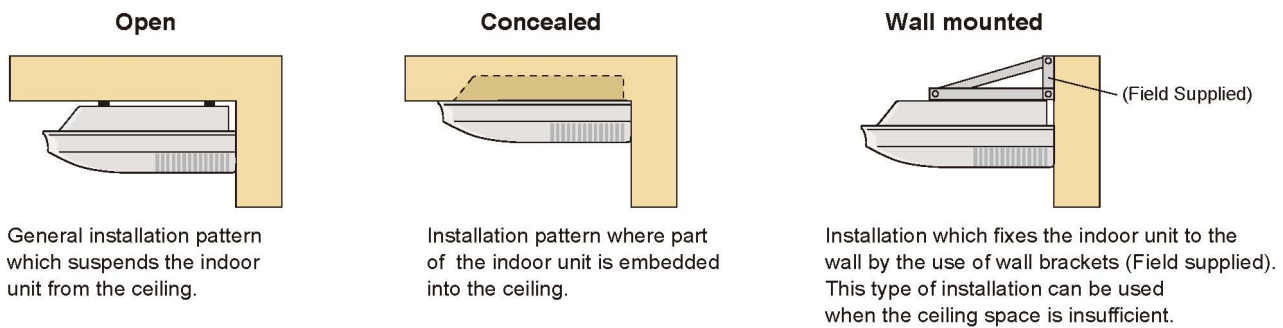

Specifications

Model name			AB*A30LBTH	AB*A36LBTH	AB*A45LBTH	AB*A54LBTH
Power source			230V ~, 50Hz			
Capacity	Cooling	kW	9.0	11.2	12.5	14.0
	Heating		10.0	12.5	14.0	16.0
Input power		W	66	85	131	180
Airflow rate	High	m ³ /h	1,630	1,690	2,010	2,270
	Med		1,370	1,400	1,600	1,780
	Low		1,140	1,170	1,230	1,280
Sound pressure level	High	dB(A)	42	45	48	51
	Med		38	38	42	45
	Low		33	34	35	36
Dimensions (H x W x D)		mm	240 x 1,660 x 700			
Weight		kg	47	48		
Connection pipe diameter	Liquid (Flare)	mm	ø9.52	ø9.52		
	Gas (Flare)		ø15.88	ø19.05		
	Drain		ø25 (I.D.) ; ø32 (O.D.)			

AB*: ABY(FUJITSU), ABH(GENERAL)

Note : Specifications are based on the following conditions.

Cooling : Indoor temperature of 27°CDB / 19°CWB, and outdoor temperature of 35°CDB / 24°CWB.

Heating : Indoor temperature of 20°CDB / (15°CWB), and outdoor temperature of 7°CDB / 6°CWB.

Pipe length : 7.5 m; Height difference between outdoor unit and indoor unit : 0 m.

Voltage : 230 [V].

Double auto swing and wide airflow

Auto airflow direction and auto swing

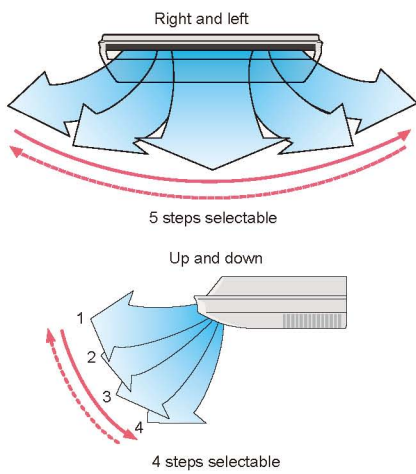

Long airflow

Long Airflow ensures comfort to every corner of a large room.

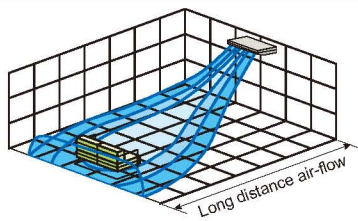

Slim & Compact design

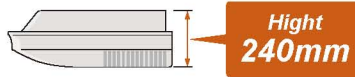

Condensate lift-up mechanism (Option)

Optional drain lift-up mechanism allows flexible installation.

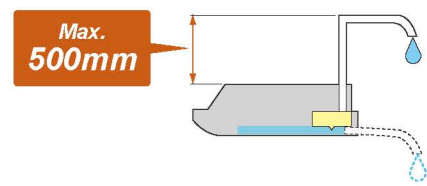

Fresh air intake

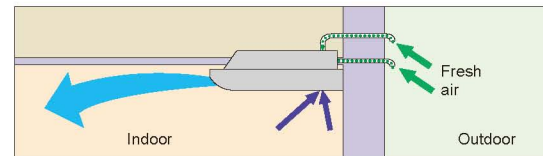

High power DC fan motor

- High power
- Wide rotation range
- High efficiency

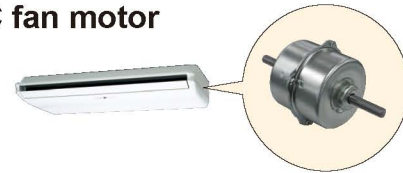

Long-life filter

High Efficiency long-life filter doubles the life of the filter compared to standard filters.

Optional parts

Drain Pump Unit : UTR-DPB24T
Flange : UTD-RF204

Dimensions (Unit : mm)

Models: AB*A30 / AB*A36 / AB*A45 / AB*A54

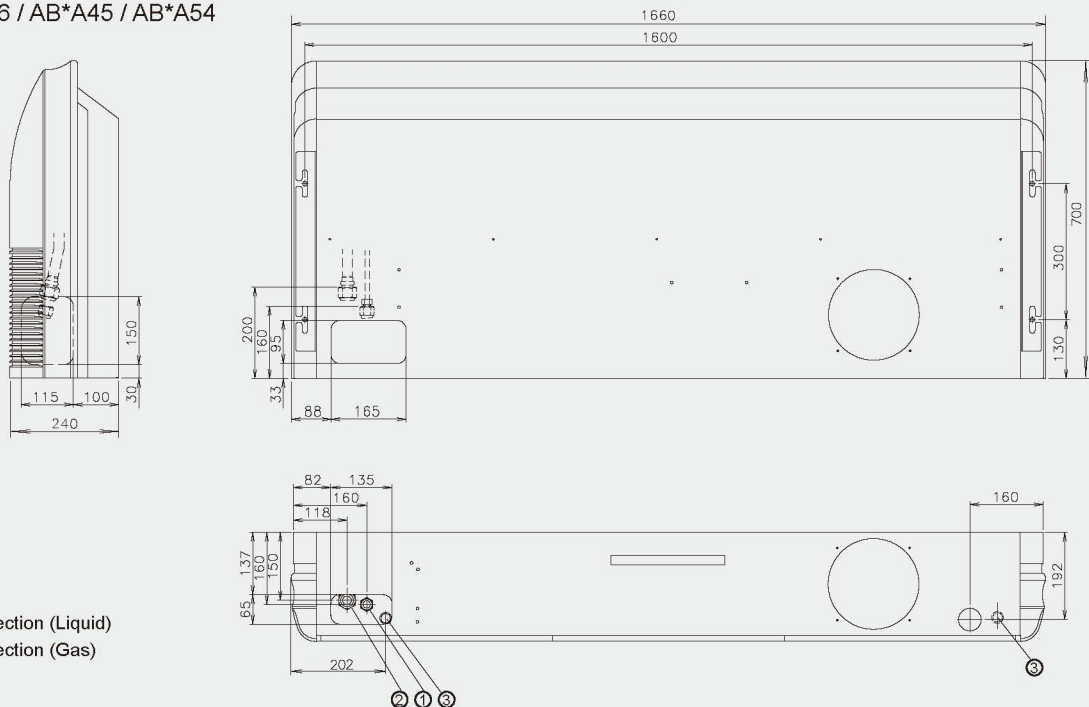

Compact Wall Mounted

Models (EEV internal model)

AS*A07LACH
AS*A09LACH
AS*A12LACH
AS*A14LACH

Models (EEV external model)

AS*E07LACH
AS*E09LACH
AS*E12LACH
AS*E14LACH



Compact and Stylish design indoor

Filter features

High quality air conditioning by incorporation of high performance filter.



Long-life* Ion Deodorization Filter

The filter deodorizes by powerfully decomposing absorbed odors using the oxidizing and reducing effects of ions generated by the ultra-fine-particle ceramic.

(*The filter can be used for approx. 3 years if it is washed under water to restore its surface action when it is dirty.)



Apple-catechin Filter

Fine dust, invisible mold spores, and harmful microorganisms are absorbed onto the filter by static electricity, and further growth is inhibited and deactivated by the polyphenol extracted from apples.

Deodorizing effect (Odor reduction rate)

Ammonia

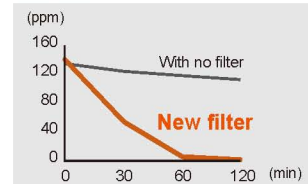

Trimethylamine

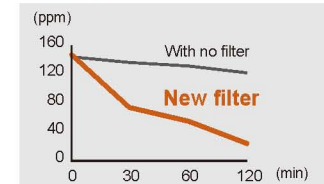

Hydrogen sulfate

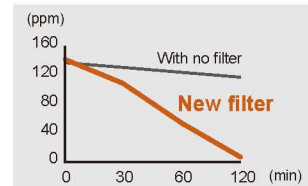

Testing organization :
 Environmental Sanitary Inspection Center
 Test method :
 Deodorization Test

Specifications

Model name			AS*A07LACH	AS*A09LACH	AS*A12LACH	AS*A14LACH	AS*E07LACH	AS*E09LACH	AS*E12LACH	AS*E14LACH
Power source			230V ~, 50Hz				230V ~, 50Hz			
Capacity	Cooling	kW	2.2	2.8	3.6	4.5	2.2	2.8	3.6	4.5
	Heating		2.8	3.2	4.1	5.0	2.8	3.2	4.1	5.0
Input power		W	16	16	19	30	15	16	20	28
Airflow rate	High	m³/h	490	500	560	670	490	500	560	680
	Med		450	450	480	490	450	450	480	490
	Low		370	370	420	420	370	370	420	420
Sound pressure level	High	dB(A)	35	36	39	44	34	35	38	43
	Med		33	33	35	37	32	32	34	35
	Low		27	27	31	32	26	26	30	30
Dimensions (H x W x D)		mm	275 x 790 x 215				275 x 790 x 215			
Weight		kg	9				9			
Connection pipe diameter	Liquid (Flare)	mm	ø6.35				ø6.35			
	Gas (Flare)		ø12.70				ø12.70			
	Drain		ø13.8(I.D.) ; ø15.8-ø16.7(O.D.)				ø13.8(I.D.) ; ø15.8-ø16.7(O.D.)			
EV Kit (option)			—				UTR-EV09XB		UTR-EV14XB	

AS*: ASY(FUJITSU), ASH(GENERAL)

Note : Specifications are based on the following conditions.

Cooling : Indoor temperature of 27°CDB / 19°CWB, and outdoor temperature of 35°CDB / 24°CWB.

Heating : Indoor temperature of 20°CDB / (15°CWB), and outdoor temperature of 7°CDB / 6°CWB.

Pipe length : 7.5 m; Height difference between outdoor unit and indoor unit : 0 m.

Voltage : 230 [V].

Low noise

Electronic Expansion valves are built-in allowing for easy installation.

For installation to places that require additional low noise, select the external electronic expansion valve type.

27dB
(AS07/09)



Auto swing louvre

The Auto Swing Louvre function ensures that the air direction corresponds to the mode selected.

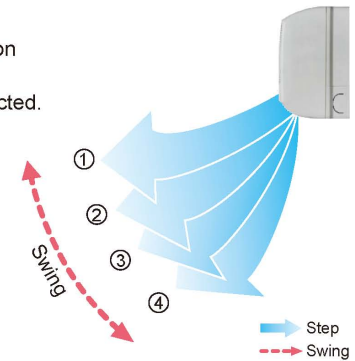

Compact size

Powerful output even compact design

**Width
790mm**

Though the indoor unit is compact, it features a large, high pressure cross fan (90mm diameter) in a centre mounted configuration and a Lambda type heat exchanger to provide plenty of power.

Easy maintenance

Easy maintenance has been realized as the front panel can be removed for easy access.



Symmetrical design

Symmetrical, clean design that suits all interiors.

New style high power DC fan motor

- High power
- Wide rotation range
- High efficiency
- Compact size

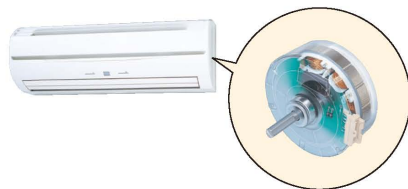

Wired control compatible

Wired and Wireless Remote Controller are acceptable.



Wired Remote Controller



Simple Remote Controller

Dimensions (Unit : mm)

Models: AS*A07 / AS*A09 / AS*A12 / AS*A14
AS*E07 / AS*E09 / AS*E12 / AS*E14

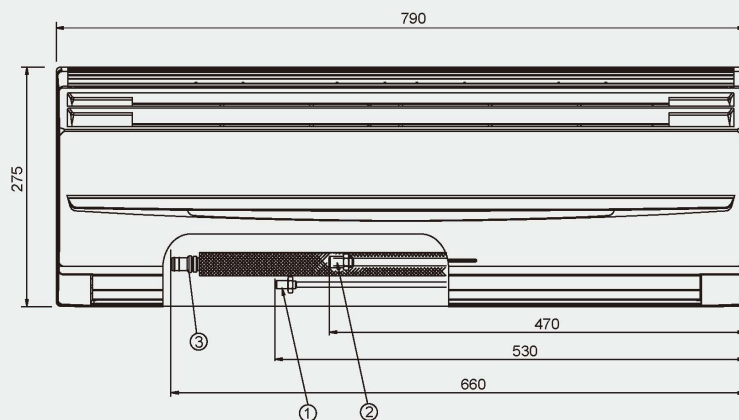

- ① Refrigerant pipe flare connection (Liquid)
- ② Refrigerant pipe flare connection (Gas)
- ③ Drain piping connection

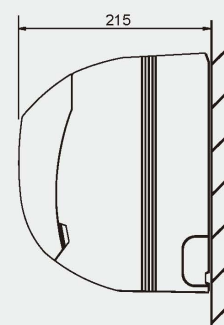

EV kit (UTR-EV09XB/ UTR-EV14XB) Optional parts:

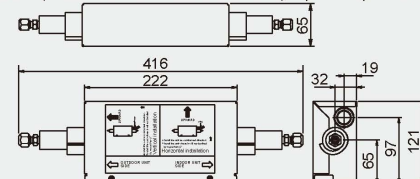

Wall Mounted

Models

AS*A18LACH

AS*A24LACH

AS*A30LACH

Simple & Elegant Appearance Design



Compact & Slim design

By using DC fan motor, compact design is realized.

New model



Previous model



Specifications

Model name			AS*A18LACH	AS*A24LACH	AS*A30LACH
Power source			230V ~, 50Hz		
Capacity	Cooling	kW	5.6	7.1	8.0
	Heating		6.3	8.0	9.0
Input power		W	35	64	91
Airflow rate	High	m ³ /h	840	1,100	1,240
	Med		770	910	980
	Low		690	730	770
Sound pressure level	High	dB(A)	41	48	52
	Med		39	43	45
	Low		35	35	35
Dimensions (H x W x D)		mm	320 x 998 x 228		
Weight		kg	15		
Connection pipe diameter	Liquid (Flare)	mm	ø9.52		
	Gas (Flare)		ø15.88		
	Drain		ø12 (I.D.) ; ø16 (O.D.)		

AS*: ASY(FUJITSU), ASH(GENERAL)

Note : Specifications are based on the following conditions.

Cooling : Indoor temperature of 27°CDB / 19°CWB, and outdoor temperature of 35°CDB / 24°CWB.

Heating : Indoor temperature of 20°CDB / (15°CWB), and outdoor temperature of 7°CDB / 6°CWB.

Pipe length : 7.5 m; Height difference between outdoor unit and indoor unit : 0 m.

Voltage : 230 [V].

“Vertical airflow” provides powerful floor level heating

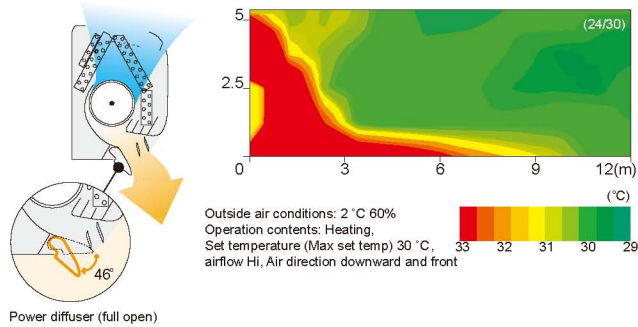

“Horizontal airflow” does not blow cool air directly at the occupants in the room

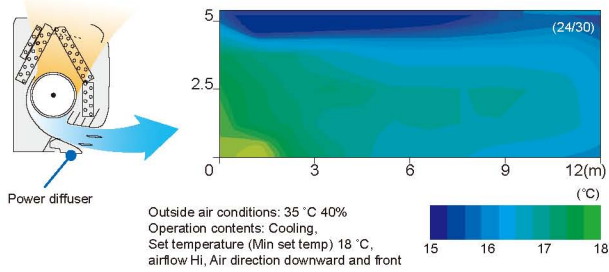

Easy maintenance

Simplification of drain pan cleaning improves maintenance-ability.

Air conditioner filter features

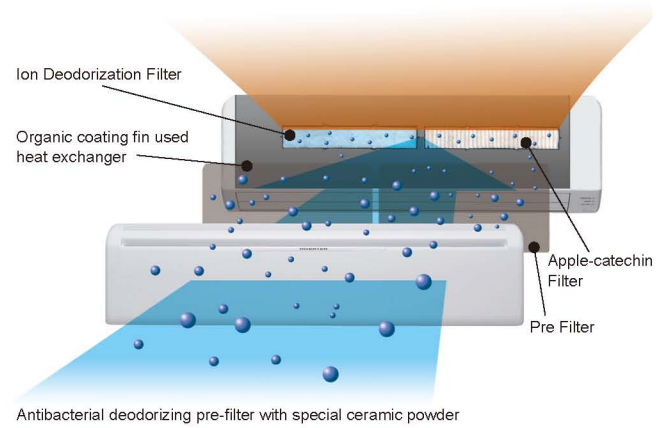

Long-life* Ion Deodorization Filter

The filter deodorizes by powerfully decomposing absorbed odors using the oxidizing and reducing effects of ions generated by the ultra-fine-particle ceramic.

(*The filter can be used for approx. 3 years if it is washed under water to restore its surface action when it is dirty.)

+ Using different filters at both sides

Apple-catechin Filter

Fine dust, invisible mold spores, and harmful microorganisms are absorbed onto the filter by static electricity, and further growth is inhibited and deactivated by the polyphenol extracted from apples.

Dimensions (Unit : mm)

Models: AS*A18 / AS*A24 / AS*A30

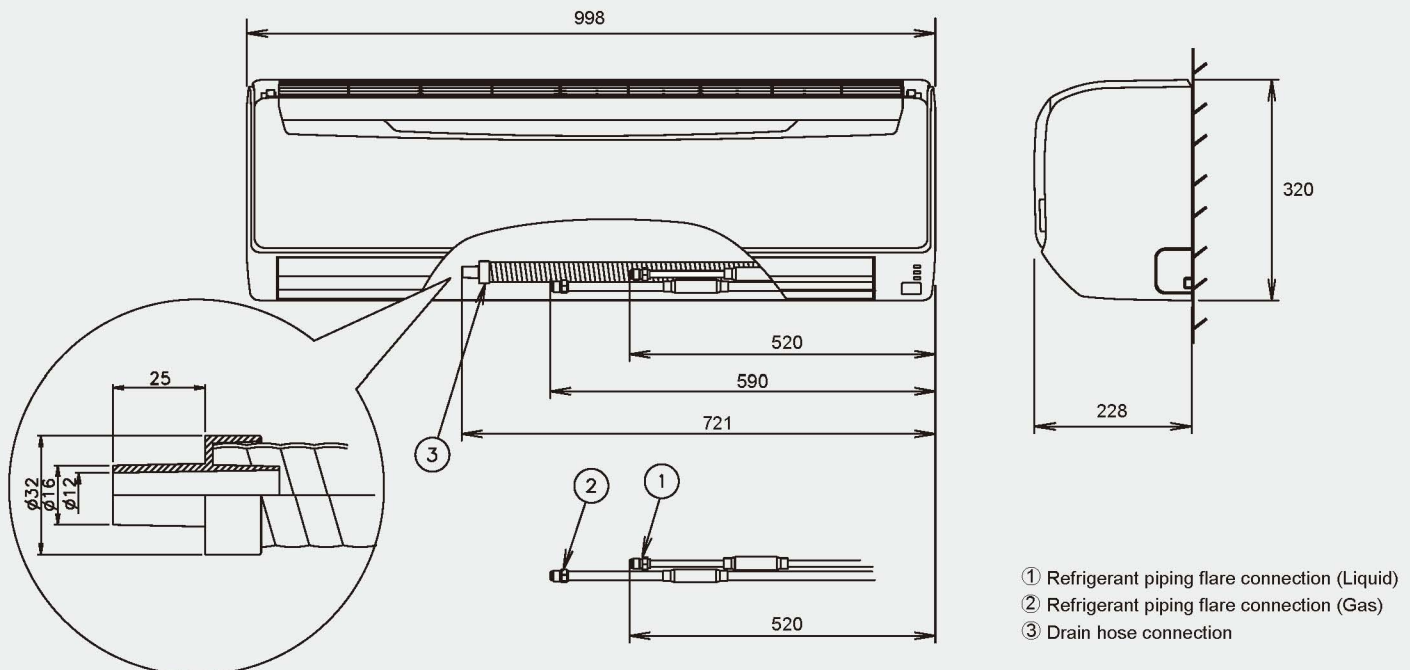

Control System Diagram

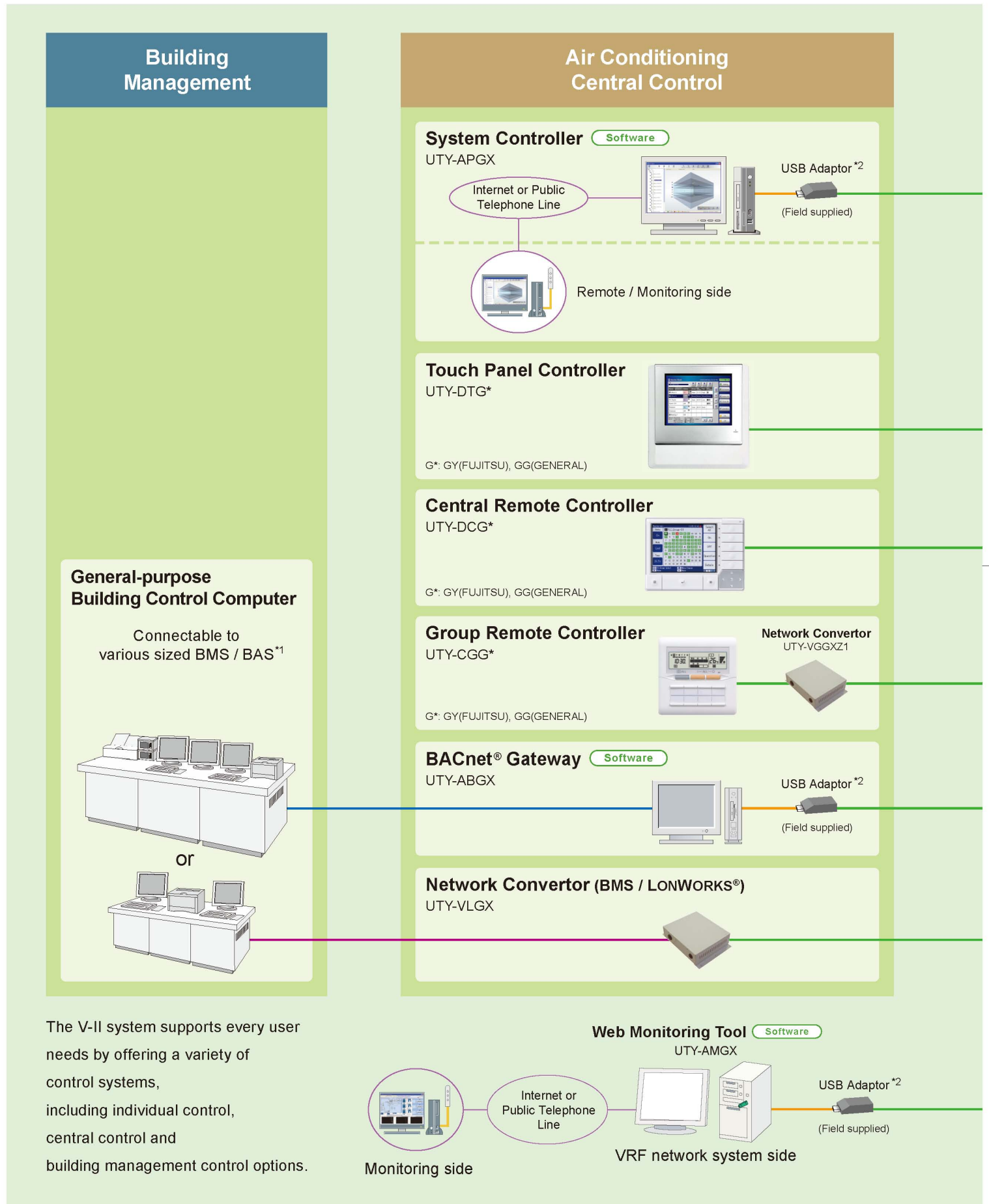

*1. BMS/BAS: Building Management System / Building Automation System *2. USB Adaptor is U10 USB Network Interface of Echelon® Corporation.

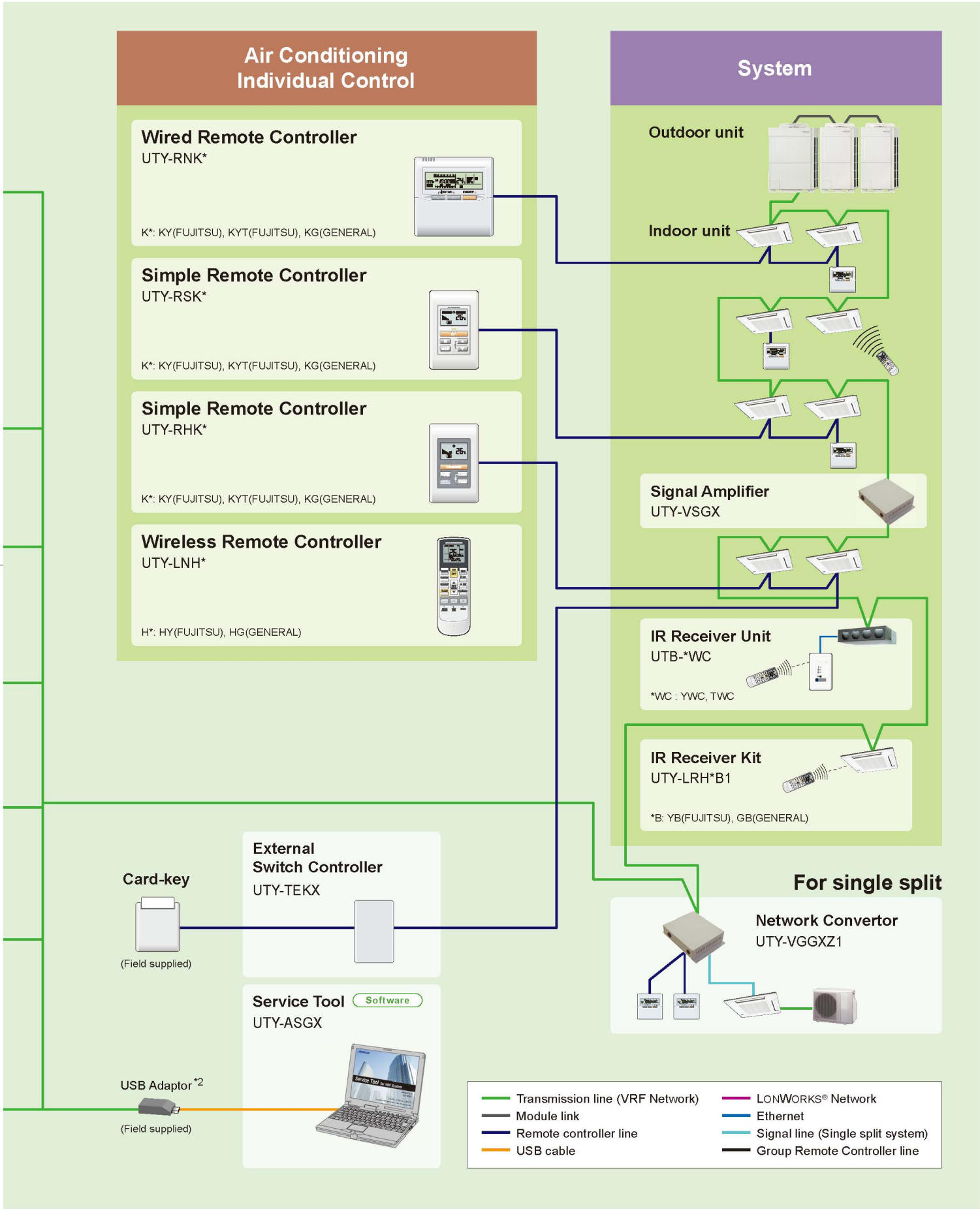

Air Conditioning Individual Control

Wired Remote Controller
UTY-RNK*

K*: KY(FUJITSU), KYT(FUJITSU), KG(GENERAL)

Simple Remote Controller
UTY-RSK*

K*: KY(FUJITSU), KYT(FUJITSU), KG(GENERAL)

Simple Remote Controller
UTY-RHK*

K*: KY(FUJITSU), KYT(FUJITSU), KG(GENERAL)

Wireless Remote Controller
UTY-LNH*

H*: HY(FUJITSU), HG(GENERAL)

System

Outdoor unit

Indoor unit

Signal Amplifier
UTY-VSGX

IR Receiver Unit
UTB-*WC

*WC : YWC, TWC

IR Receiver Kit
UTY-LRH*B1

*B: YB(FUJITSU), GB(GENERAL)

For single split

Network Converter
UTY-VGGXZ1

Card-key

(Field supplied)

External Switch Controller
UTY-TEKX

Service Tool Software
UTY-ASGX

USB Adaptor *2

(Field supplied)

- Transmission line (VRF Network)
- Module link
- Remote controller line
- USB cable
- LONWORKS® Network
- Ethernet
- Signal line (Single split system)
- Group Remote Controller line

Wiring system

Max. transmission line length
3,600m



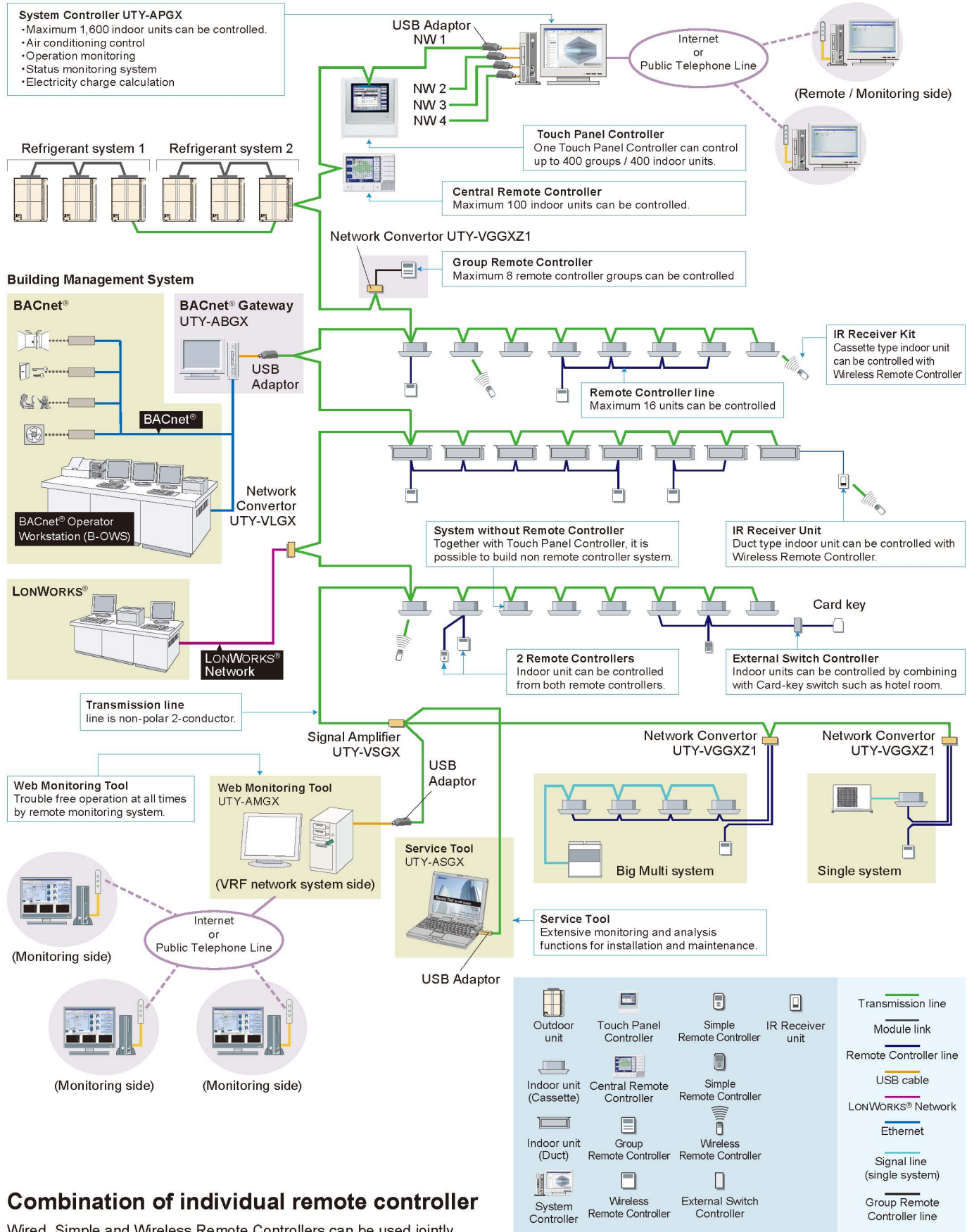





- Wiring construction of the control system is made of power source wiring, transmission wiring and remote controller wiring.
- Total wiring length (total length of transmission line) can be extended up to 3,600m (by using signal amplifiers).



Combination of individual remote controller

Wired, Simple and Wireless Remote Controllers can be used jointly.

Comparison table of Controllers

Item										
Model name	UTY-RNKY UTY-RHKYT UTY-RNKG	UTY-RSKY UTY-RSKYT UTY-RSKG	UTY-RHKY ^{*1} UTY-RHKYT UTY-RHKG	UTY-LNHY UTY-LNHG	UTY-CGGY UTY-CGGG	UTY-DCGY UTY-DCGG	UTY-DTGY UTY-DTGG	UTY-APGX <small>(Software)</small>		
Max. controllable remote controller groups	1	1	1	1	8	100	400	1600		
Max. controllable indoor units	16	16	16	16	96	100	400	1600		
Max. controllable groups	-	-	-	-	-	16	400	1600		
Air conditioning control function	On / Off	●	●	●	●	●	●	●		
	Operation mode setting	●	●	-	●	●	●	●		
	Fan speed setting	●	●	●	●	●	●	●		
	Room temp. setting	●	●	●	●	●	●	●		
	Room temp. set point limitation	-	-	-	-	-	●	●		
	Test operation	●	●	-	●	-	●	●		
	Up/down air direction flap setting	●	-	-	●	-	●	●		
	Right/left air direction flap setting	●	-	-	●	-	●	●		
	Group setting	-	-	-	-	-	●	●		
	RC prohibition	-	-	-	-	-	●	●		
	Anti freeze setting	-	-	-	-	-	●	●		
	Economy mode setting	●	-	-	●	-	●	●		
Display	Failure	●	●	●	-	●	●	●		
	Defrosting	●	●	●	-	-	●	●		
	Current time	●	-	-	●	●	●	●		
	Day of week	●	-	-	-	●	-	●		
	R.C. prohibition	●	●	●	-	-	●	●		
	Cooling/heating priority	●	●	●	-	●	●	●		
	Address display	●	●	●	-	●	●	●		
Timer	Schedule timer	Period	Week	-	-	-	Week	Week	Year	Year
		On/off per day	4	-	-	-	4	20	20	72
		On/off per week	28	-	-	-	28	140	140	504
	On/off timer	●	-	-	●	-	-	-	-	
	Sleep timer	-	-	-	●	-	-	-	-	
	Program timer	-	-	-	●	-	-	-	-	
	Day off	●	-	-	-	-	●	●	●	
Min. unit of timer setting (Minutes)	30	-	-	5	10	10	10	10		
Control	Status monitoring system	-	-	-	-	-	●	●		
	Electricity charge calculation	-	-	-	-	-	-	●		
	Error history	●	●	●	-	●	●	●		
	Emergency stop	-	-	-	-	-	● ^{*2}	● ^{*2}	-	
	Control via internet	-	-	-	-	-	-	-	●	
	E-mail notification for malfunction	-	-	-	-	-	-	-	●	

*1 "Operation mode" setting is not available for this model.

*2 This function is available only through external input. control.

Wired Remote Controller

UTY-RNK*

Max. controllable
16
indoor units

The room temperature can be controlled by detecting the temperature accurately from the built-in sensor

- Simple operation with Built-in Weekly / Daily Timer.
- Control up to 16 indoor units.
- Up to 2 wired remote controllers can be connected to a single indoor unit.

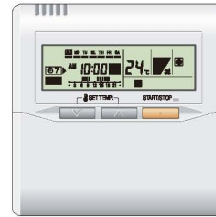

Functions

Powerful features and compact size

This Wired Remote Controller incorporates four primary functions into a single unit.



Built-in timers

Easy-to-understand time bar display

Weekly timer : Possible to set ON/OFF time to operate twice each day of the week.



Setup screen example
Set to Wednesday: 8:00 to 20:00.

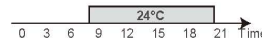

Screen after setup



Setback timer : Possible to set temperature for two times spans and for each day of the week.

Setup screen example
Set from Sunday to Saturday: 12:00 to 15:00, 28°C.



At "Weekly timer" + "Set back timer" setup

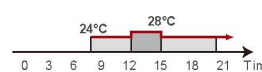

24°C → 28°C → 24°C

Accurate and comfortable

Indoor temperature can be detected accurately by the inclusion of a thermo sensor in the body of the wired controller. This new wired remote controller and the optional remote sensor allows flexibility in sensor location, suitable for all requirements.

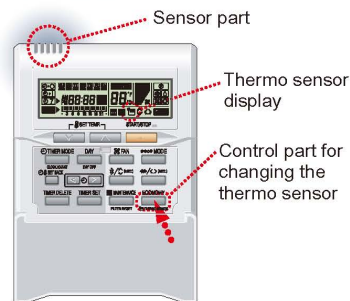

Example of changing sensor

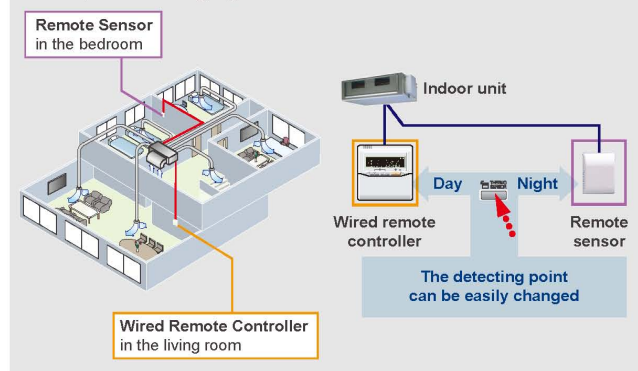

Displayed temperature is set temperature.

Diagnosis check function

Two methods are available for determining the cause of failure in the event of a malfunction occurs:

- Malfunction diagnosis function
- Error history (Last 16 error codes can be accessed)

Simple installation

Components are compatible with standard switch boxes. Flat back surface allows to be installed wherever it is needed.

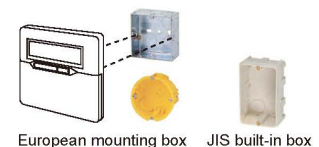

Specifications

Model name	UTY-RNK*
Power Supply	DC 12V
Dimensions (H x W x D) (mm)	120 x 120 x 17
Weight (g)	160

DC12V is supplied by the indoor unit. K* : KY(FUJITSU), KYT(FUJITSU), KG(GENERAL)

Simple Remote Controller

Max. controllable
16
indoor units

UTY-RSK*

UTY-RHK* (Without Operation mode)

Compact remote controller provides access to basic functions

- Up to 16 indoor units can be controlled with one remote controller.
- Suitable for hotels or offices as it is easily operated with no complex functions.



UTY-RSK*



UTY-RHK*
Without Operation mode

Functions

User-friendly operation

- Provides access to basic operations, such as Start / Stop, Fan control, Operation mode switching, and Room temperature setting.
- A large On / Off button is provided in the centre of the remote controller for easy operation.
- Can be used jointly with other individual control unit.
- Following an error display, diagnostics can be carried out on the controller.

Background light

- Background light enables easy operation in a darkened room.
- Background light activates during all button operations, and lasts 10 seconds in Operation mode and 5 seconds in stop mode after a button is pressed.



Simple installation

Can be mounted on the European Mounting Box (Installation dimension: 60mm) or the JIS Built-in Box (Installation dimension: 83.5mm).



Functions summary

Model	UTY-RSK*	UTY-RHK*
Operation	●	●
On / Off	●	●
Fan control	●	●
Operation mode	●	— *1
Room temp. setting	●	●

*1: "Operation mode" setting is not available.
It is recommend to use together with other type controller.

Specifications

Model name	UTY-RSK*	UTY-RHK*
Power Supply	DC 12V	
Dimensions (H x W x D) (mm)	120 x 75 x 14	
Weight (g)	90 (100 : UTY-RSKYT)	90 (100 : UTY-RHKYT)

DC12V is supplied by the indoor unit. K* : KY(FUJITSU), KYT(FUJITSU), KG(GENERAL)

Wireless Remote Controller

UTY-LNH*

Simple and sophisticated operations with a choice of 4 daily timers

• A single controller controls up to 16 indoor units.



Max. controllable
16
indoor units

Selectable
4
daily timers

Functions

Built-in daily timer

Select from 4 different timer programs :

On / Off / Program / Sleep

Program timer : The program timer operates the ON and OFF timer once within a 24 hour period.

Sleep timer : The sleep timer function automatically corrects the set temperature according to the time setting to prevent excessive cooling or heating during sleep hours.

Cooling operation/dry operation

When the sleep timer is set, the set temperature automatically rises 1°C every hour. The set temperature can rise up to a maximum of 2°C.

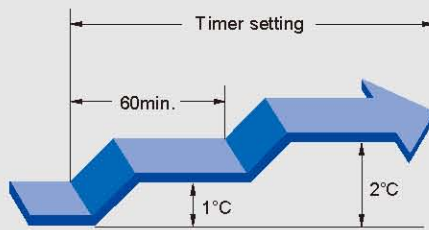

Heating operation

When the sleep timer is set, the set temperature automatically drops 1°C every 30 minutes. The set temperature can drop to a max. of 4°C.

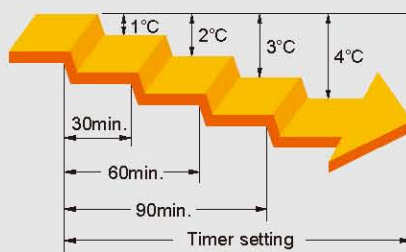

Easy installation and operation

Code selector switch prevents indoor unit mix-up. (Up to 4 codes can be set.)

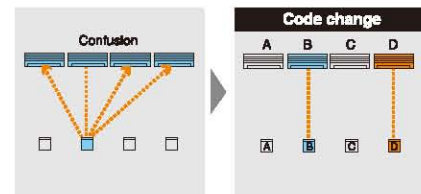

Wide and precise

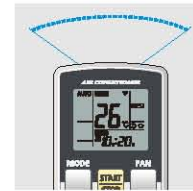

Address setting

During installation work, address setting can be performed using the Wireless Remote Controller, thus eliminating manual switch setting.

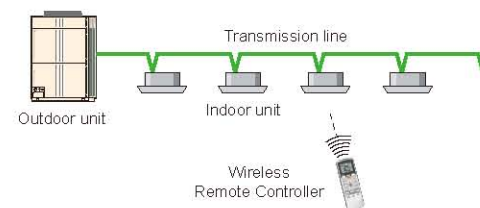

Specifications

Model name	UTY-LNH*
Battery	1.5V (R03 / LR03 / AAA) x 2
Dimensions (H x W x D) (mm)	158 x 56 x 20
Weight (g)	70

H* : HY(FUJITSU), HG(GENERAL)

IR Receiver Unit

UTB-*WC

Necessary to control for all duct type by Wireless Remote Controller

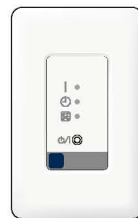

Wiring connection

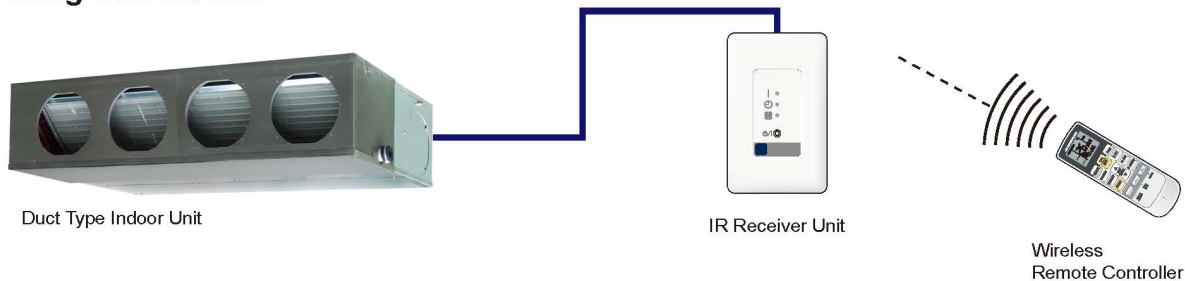

Specifications

Model name	UTB-*WC
Battery	DC 12V
Dimensions (H x W x D) (mm)	122 x 60 x 26.5
Weight (g)	150

*WC : YWC, TWC

IR Receiver Kit

UTY-LRH*B1

Cassette type indoor unit can be controlled with Wireless Remote Controller



Specifications

Model name	UTY-LRH*B1
Battery	DC 12V
Dimensions (H x W x D) (mm)	213.8 x 213.8x 25.7
Weight (g)	140

H* : HY(FUJITSU), HG(GENERAL)

Group Remote Controller

UTY-CGG*

Group control of indoor units with simple operation

- Up to 8 remote controller groups can be controlled by one Group Remote Controller.
 - Up to 64 Group Remote Controllers can be connected in one VRF network system.
 - Network Converter (UTY-VGGXZ1) is required to connect Group Remote Controllers to a VRF network system.
- (Network Converter allows up to 4 Group Remote Controllers)

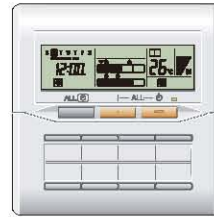

Max. controllable
8
remote controller groups

Max. connectable
64
group R.C. in a VRF network system

Functions

High performance and compact size

ON / OFF, Operating mode, Room temperature and Fan speed setting can be controlled / monitored centrally or individually.

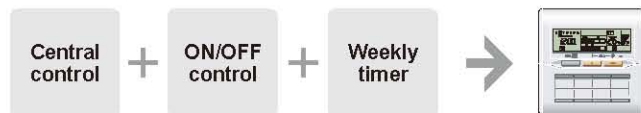

Control up to 8 remote controller groups

Single Group Remote Controller controls and monitors up to 8 remote controller groups.

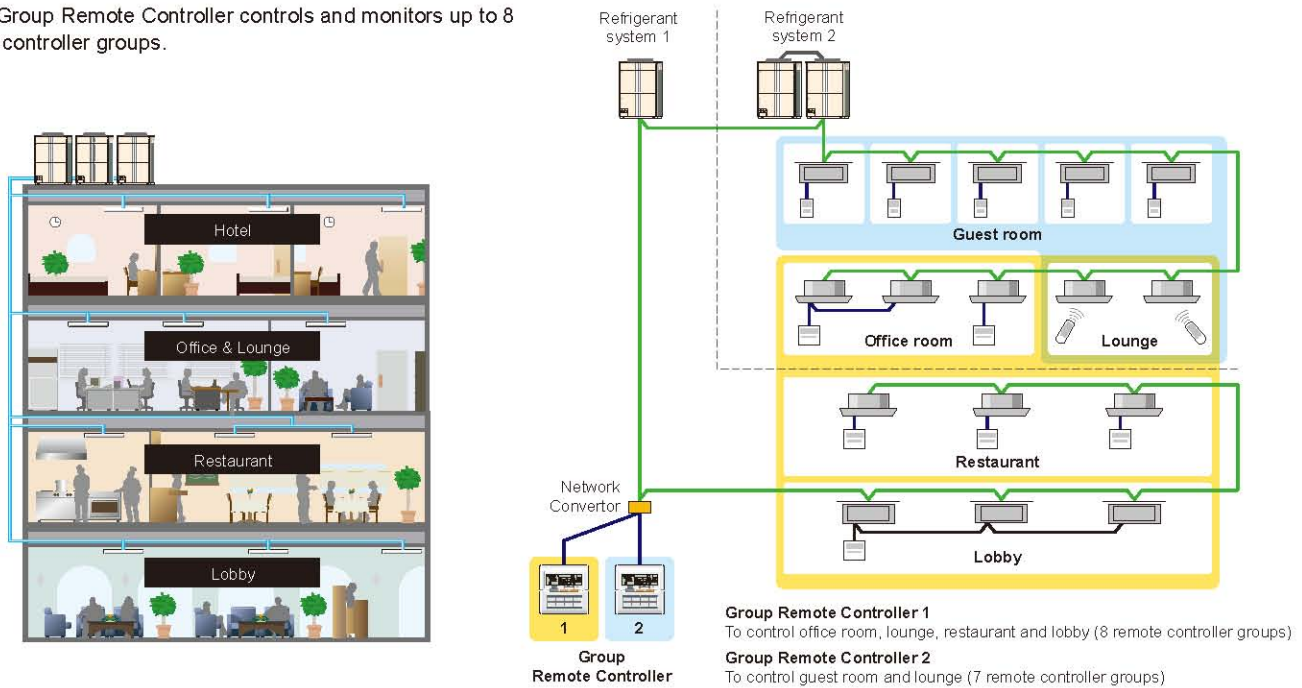

Built-in weekly timers

The weekly timer is provided as a standard function.

1. The timer can be set up for up to 4 times per day. (On / Off, operating mode, set temperature)
2. Allows separate settings for each day of the week.

ON / OFF switching

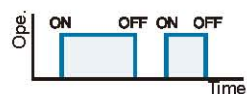

Air conditioning ON/OFF setting corresponding to air conditioning specification needs is possible.

Cooling / Heating switching

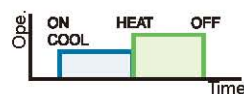

Switching between the cooling mode and heating mode can be set by time.

Temperature switching (Peak power cut)

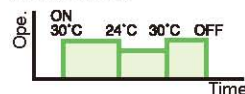

Since peak power cut is performed in a planned way, setting which changes the room temperature linked with time is possible.

Temperature switching (Anti-freeze)

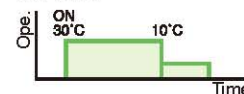

Low temperature heating operation can be set to prevent freezing in cold regions at night, etc.

Stop setting

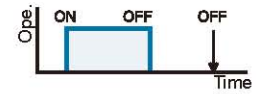

Indoor unit stop setting at operation end time is possible.

Useful functions

1 Timer setting at all the connected indoor units is possible by centralized timer on the front panel.

ALL TIMER Button
Press the ALL TIMER button to turn the timer operation on or off for all indoor units.

3 The indoor unit can be quickly turned on and off by ON / OFF button of each indoor unit on the front of the door.

Indoor Unit Name Labels
Write the names of the indoor units on the included labels and attach them.

ON / OFF Button
Press the ON / OFF button to turn the corresponding indoor unit on or off.

With cover closed

Indoor Unit Operation Indicators
Timer setting at all the connected indoor units is possible by centralized timer on the front panel.

- : On
- : Timer operation
- : Off
- ▼ : Selection

2 All the connected indoor units can be turned on / off simultaneously by centralized ON/OFF button on the front of the cover.

Operation Lamp
This is on if any of the indoor units is operating. This flashes if any of the indoor units has malfunction(s).

ALL OFF Button
Press the ALL OFF button to turn off all of the indoor units.

ALL ON Button
Press the ALL ON button to turn on all of the indoor units.

Timer and Clock Display and setting

- Setting Display
- Day Display
- Timer and Clock Display
- Timer Mode Display
- Timer Mode (DELETE) Button
- DAY Button
- Set Time Button
- PROGRAM (CLOCK ADJUST) Button
- ENTER Button

With cover open

Displaying the Status and Controlling indoor units

- Transmission Display
- Operation Lock Display
- ON / OFF Display
- Fan Speed Display
- Set Temperature Display
- Operation Mode Display
- ON / OFF Button
- Select Button
- Fan Control Button
- Master Control Button*1, *2, *3
- Set Temperature Button
- Child Lock Function

*1 : "AUTO" is not available for a heat pump model unless it is set up for the master indoor unit.

*2 : "FAN" is not available for a heat pump model

*3 : "HEAT" is not available for a cooling only model

Specifications

Model name	UTY-CGG*
Power Supply	DC 12V
Dimensions (H x W x D) (mm)	120 x 120 x 17
Weight (g)	200

DC12V is supplied by a network converter. G* : GY(FUJITSU), GG(GENERAL)

Central Remote Controller

UTY-DCG*

Central control of small- and medium-sized buildings and tenants. The operation status of all connected indoor units can be viewed at a glance on a large LCD monitor to simplify individual control to batched control.

- Individual control and monitor of 100 indoor units
- 5 inch TFT color screen
- User friendly view and easy operation
- External input / output contact
- Detachable power supply unit
- Corresponds to 7 different languages (English, Chinese, French, German, Spanish, Russian, Polish)



Max. controllable
100
Indoor units

Max. controllable
16
groups

User friendly operation

Operation status monitor displays for all indoor units
Easy comprehensible display and operation button

Function Menu
Function menu displays the items to select.

Function button
1 to 1 function button supports easy setting.

System overview

- It allows multiple indoor units grouping (Max. 16 groups controlled)
- Interlock with external device

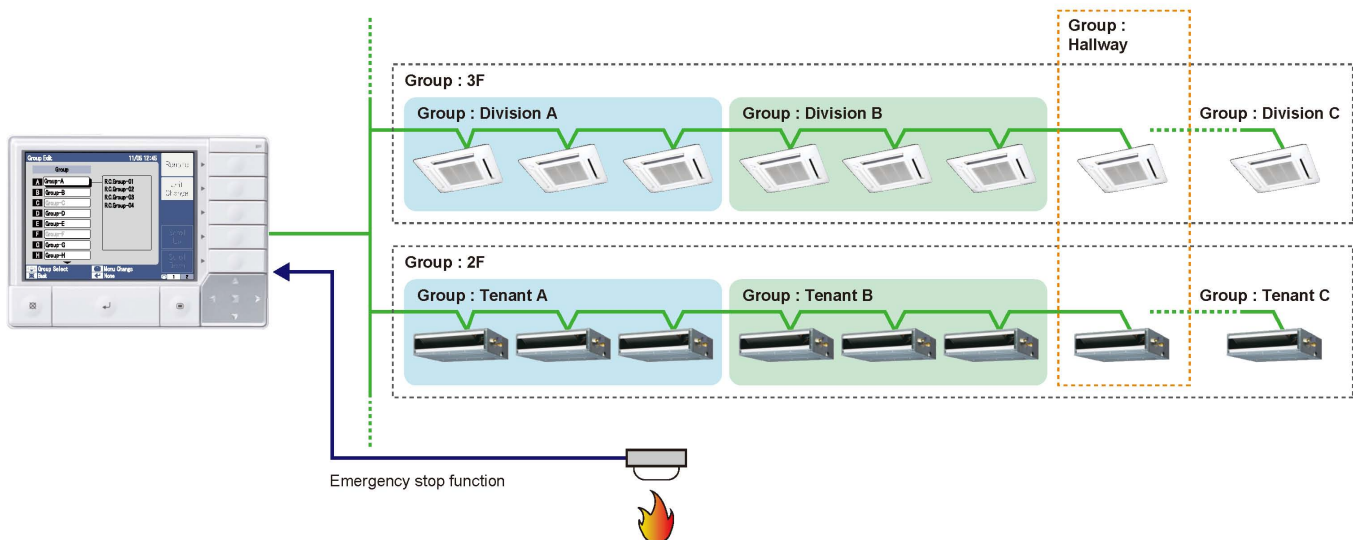

Functions

Diverse control of indoor units

- Individual control (On / Off, Mode, set Temp, Fan speed, Economy operation, Antifreeze operation)

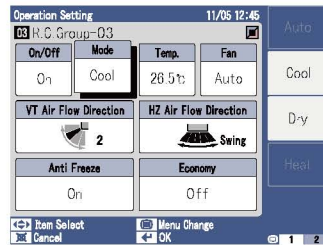

- Remote controller prohibition (All, On / Off, Mode, Temp, Timer, Filter) : R.C prohibition setting prohibits individual remote control operation from this controller

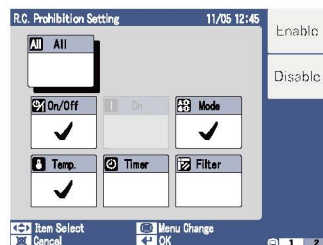

- Room temperature set point upper and lower limitation

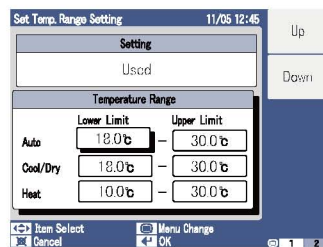

- Weekly timer : Weekly timer can set the timer by various combinations.

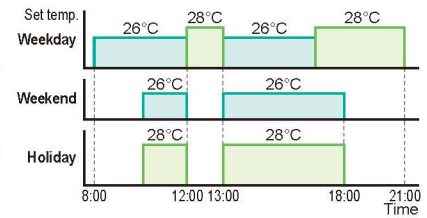
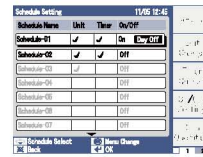

- Automatic clock adjustment :

The time setting of each controller can be set in batch automatically.



Error history

- Max 200 Errors memorize.
- Suitable maintenance is possible by analysis of the error history data.

No.	Date Time	Name	Address	Error Code
001	2009/08/01 13:05	R.C.Group-01	01-00-00	14
002	2009/08/01 13:05	R.C.Group-01	01-00-00	14
003	2009/08/01 13:05	R.C.Group-01	01-00-00	14
004	2009/08/01 13:05	R.C.Group-01	01-00-00	14

Easy Installation

- The control panel and power supply unit can be installed separately.
- For flexibility in installation, the Control panel can be built into the wall or fix on the wall.

Setting pattern 1

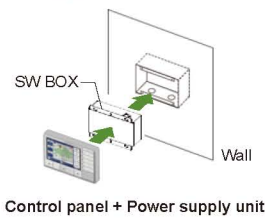

Setting pattern 2

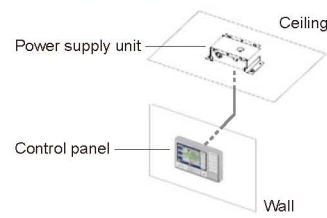

- Automatic or manual indoor unit registration

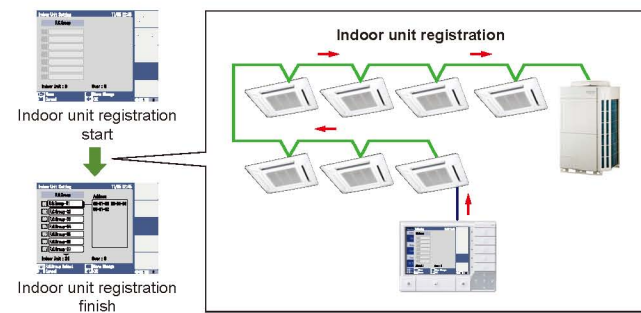

Specifications

Model name	UTY-DCG*	
	Control Panel	Power Supply Unit
Power Supply	DC 5 V	100-240V, 50-60Hz, Single phase
Dimensions (H x W x D) (mm)	120 x 162 x 26	99 x 135 x 40
Weight (g)	308	355

<PACKING LIST>

Packing List	Control Panel / Power Supply Unit / Connecting cable, etc.
--------------	--

G* : GY(FUJITSU), GG(GENERAL)

Touch Panel Controller

UTY-DTG*

Max. controllable
400
Indoor units

High visibility and easy operation via high resolution 7.5 inch TFT-LCD touch panel screen



- Large-sized 7.5-inch TFT color
- LCD Easy finger touch operation
- Stylish shape and design to suit all application
- No additional component is required for installation
- Up to 400 indoor units can be controlled
- Selectable 2 display types (Icon / List) in monitoring mode
- Corresponds to 7 different languages, English, Chinese, French, German, Spanish, Russian, Polish.

Functions

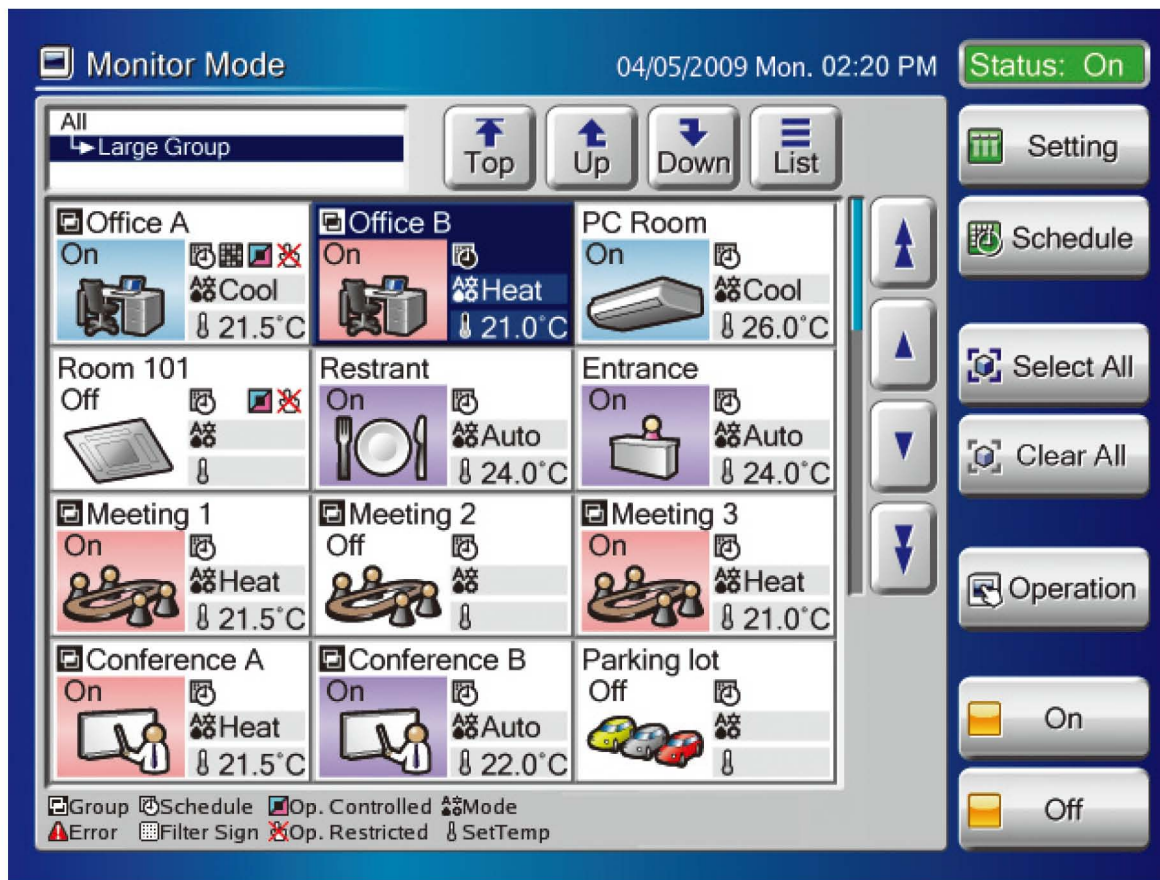

Real size screen image

Easy operation

- Large and wide-angled LCD is easily viewable even at a distance
- Easy-to-understand icon-driven Graphical User Interface (GUI)
- Wide range of simple-to-understand icons



- Operation can be selected using your finger or the dedicated touch pen by pressing the appropriate on-screen icon
- Up-to-date status display
- Background color identifies current control operation Blue for monitoring, green for operational control

Easy maintenance

- Flat touch screen is easily cleaned
- Non-glare coating on touch panel controller minimizes fingerprint marking
- Easy-to-remove front cover



Up to 400 indoor units can be controlled

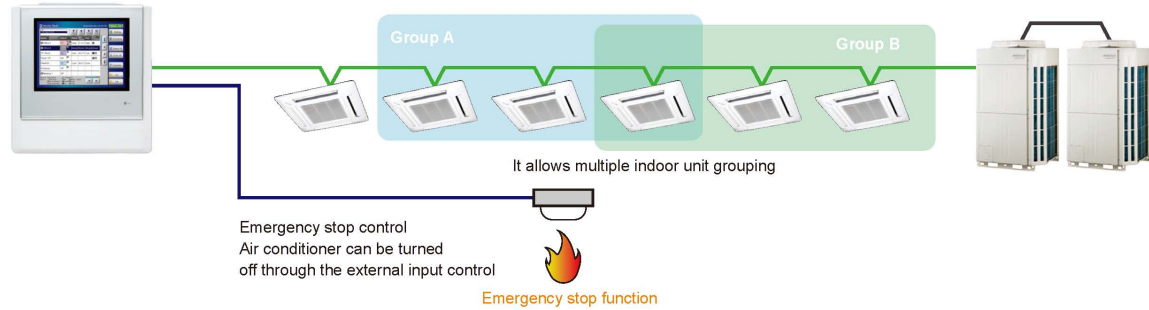

Function

- Up to 400 indoor units can be controlled
- It allows multiple indoor units grouping
- Schedule timer function is standard (20 patterns per day)
- Emergency stop function(through the external input control)
- Temperature upper and lower limit setting
- The clock of each indoor unit correct setting



Individual control



Flexible grouping



Schedule control



Indoor units operation monitoring

Versatility

CSV format data edited by PC can be imported to Touch Panel Controller.

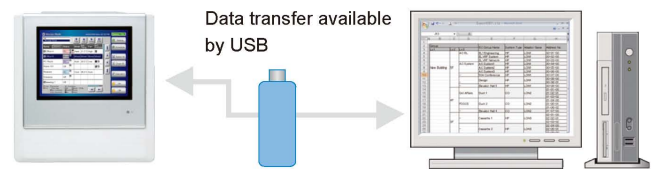

Easy installation

Touch Panel Controller is easily mounted to the wall Flat back surface allows to be installed wherever it is needed.

- Correctable mechanism for tilting (horizontal) after the installation of the body

No additional component is required for installation

- There is no need for the installation space of power supply adaptor and transmission adaptor etc.



Automatic clock adjustment

The time setting of each controller can be set in batch automatically.

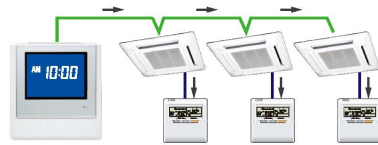

Specifications

Model name	UTY-DTG*
Power Supply	100-240V 50/60Hz
Dimensions (H x W x D) (mm)	260 x 246 x 54
Weight (g)	2,150
Interface	USB 2.0

G* : GY(FUJITSU), GG(GENERAL)

System Controller

Software

UTY-APGX

System Controller realizes the advanced integrated monitoring & control of VRF network system from small scale buildings to large scale buildings.

- Up to a maximum of 4 VRF network systems, 1600 indoor units, and 400 outdoor units can be controlled.
- Supports VRF S series, V series and V-II series.
- In addition to air conditioning precision control function, central remote control, electricity charge calculation, schedule management, and energy saving functions are strengthened and building manager and owner needs are met.

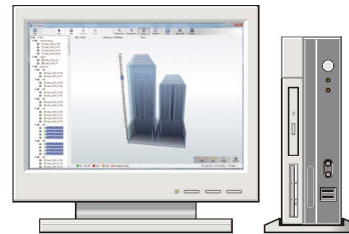

Max. controllable
4
VRF network systems

Max. controllable
400
Outdoor units

Max. controllable
1,600
Indoor units

Functions

User friendly view and operation

- **Click & Operate** : The property is shown visually from the perspective most suitable for operation and operated accordingly (Click & Operate). You can select from among the 4 displays of site, building, floor, or list.
- **Freely define groups for batched control** : Indoor units can be freely grouped for simple batched control from a tree menu. Grouping by hierarchal structure, such as by section, division or department is possible.

Click & Operate the whole building!

Properties can be shown using one of the four displays of site, building, floor, or list.

Click & Operate any specified unit(s)!

The display is easily changed by pressing the button.

Batched control of freely defined groups

Batched control of freely selected units

Click & Operate the whole floor!

The floor layout drawing can be imported to easily make the settings for the actual building.

Click & Operate the unit!

Site view

Building view

Floor view

List view

Energy saving management

With UTY-PEGX Option

Peak cut operation Option

A power meter is connected to detect the total power consumption while shifting the indoor unit set temperature, set the indoor unit forced thermostat off, and taking other measures to carefully control the power consumed while maintaining comfort and conducting control to maintain the target power consumption set for each time. The indoor units to be controlled can be freely grouped and the control level can be set.

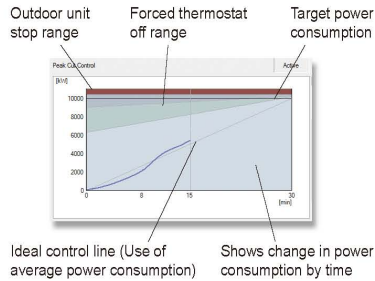

Outdoor unit capacity save Option

Outdoor unit capacity save switches the outdoor unit capability upper limit to suppress power consumption during hot summers and cold winters by averaging the power saving effect of each refrigerant system. You can select from 50% or more of the capacity upper limit.

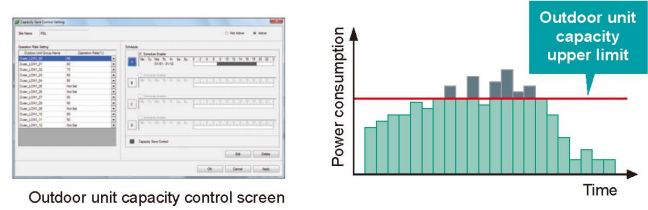

Indoor unit rotation operation Option

The operation of indoor units can be automatically rotated within a group in accordance with the set annual schedule to reduce power consumption while maintaining comfort. The indoor unit operation stoppage rate can be selected.



Batched stop

Batched stop at a freely set time for a property, building, or freely set block unit can be done to prevent any air conditioning unit from being forgotten to be turned off at the end of office hours, etc. In addition, any air conditioning unit whose operation is left on can be immediately identified by the icon color for a building or indoor unit in the monitoring screen and batched stop conducted in response.



Electricity charge apportionment

Electricity charge apportionment calculation framework

Suppose you want to find the power consumed by the air conditioners of each tenant from the electricity charge for each month. With electricity charge apportionment function, used energy apportionment ratio will be provided, calculating in detail the energy consumed by the units used by each tenant. This information is then used to calculate the charges for the electricity consumed for air conditioning by each tenant from the total electricity charges in the bill from the electric power company. (See figure at right)

The detailed calculation takes into consideration such things as unused rooms and nighttime electricity charges and shows them in a charges calculation sheet.

System Configuration Example

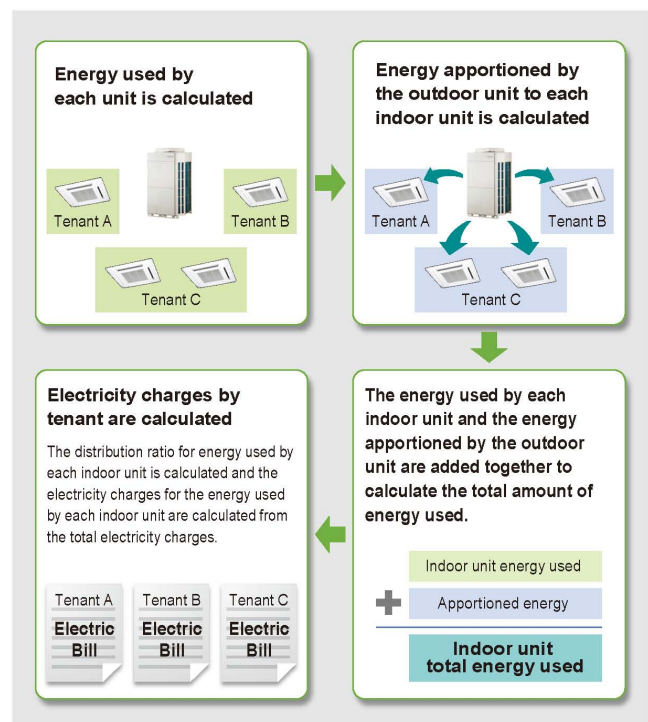
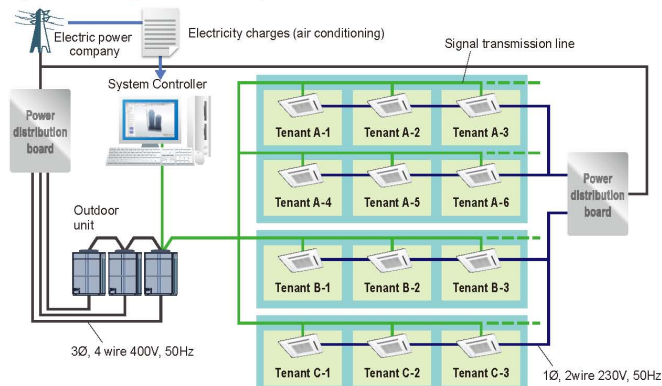

Remote centralized control

System Controller may be used on site or remotely over various networks for remote central control. System Controller requires 2 softwares working together. VRF Controller runs on site and communicate with VRF system. VRF Explorer runs remotely and provides user interface and communicate with the VRF Controller. VRF Controller and VRF Explorer program may run in a single PC or in different PCs separated by network. By using VRF Explorer software, one PC can perform central control of 10 VRF system sites with max. 20 buildings per site.

On site central control

Max. 4 VRF network systems per site

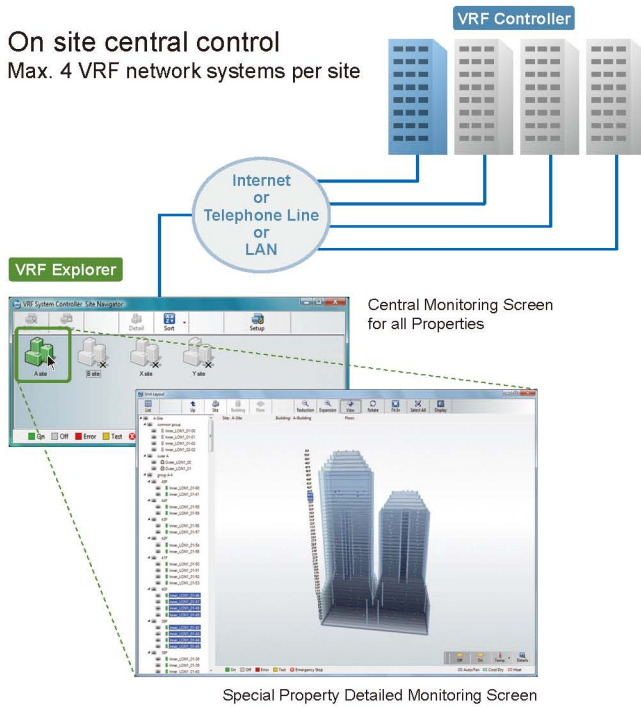

Remote central control

1 VRF Explorer can control or monitor up to 10 sites.

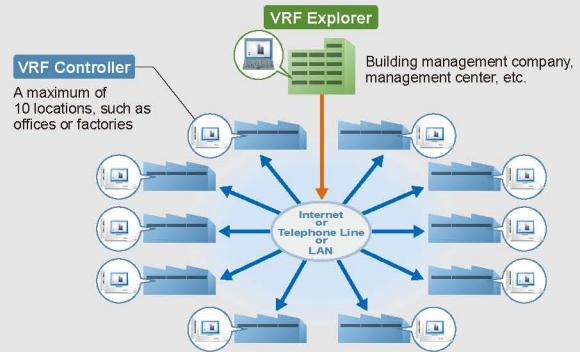

1 VRF Controller can be monitored from any number of VRF Explorers (Up to 5 connections simultaneously).

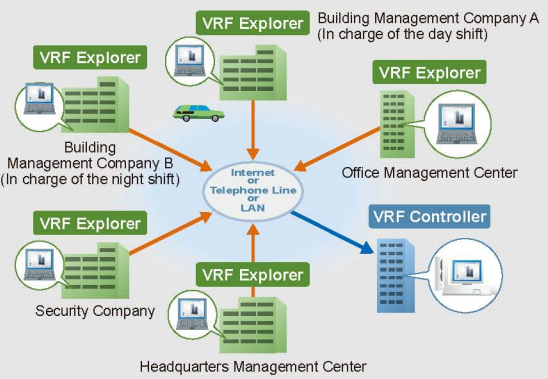

Can be used for a variety of applications

Air conditioning management for large shopping malls or the outlets of nationwide franchises

- Remote centralized management can be used for nighttime only to manage the air conditioning of multiple stores, operate air conditioning for people working overtime, and checking to see if employees forgot to turn off the air conditioning after they leave.
- Multiple users via a LAN can control the air conditioning in the office, general affairs department, or janitor's room.
- The air conditioning for franchise locations nationwide can be centrally controlled from headquarters to facilitate operation status and control to save energy.



Air conditioning management of multiple buildings spread over a large site

- Batched operation of the factory buildings on a large site can be remotely conducted from the management office of the administration building to employ power saving operation.
- The headquarters can conduct centralized remote monitoring of the company's factories in outlying areas to improve the power saving effect for the entire company.
- Controlling the operation of each building and each classroom on campus makes it possible to reduce expenses by remotely controlling those spaces in accordance with the teaching schedule.



Provides high-quality building air conditioning service

- Service companies that manage buildings that are empty at night after the managers leave to go home can conduct centralized remote monitoring of the building without dispatching employees to the site, which allows them to monitor the air conditioning for multiple clients.
- The System Controller remote monitoring and control functions can be used to receive outsourcing business from small and medium size building owners to manage their air conditioning energy.
- Nighttime only remote monitoring of multiple properties after the people leave can be performed for areas that require 24-hour operation, such as server rooms, to monitor for problems.



Security Support



Employs SSL Encryption Technology

Encryption technology is used for communications to remote sites to prevent information from being stolen.



Detailed User Management

User identification : Authorization using user IDs and passwords is employed to prevent unauthorized access.

Access authority : The functions that can be used are restricted for individual login users to prevent unauthorized use.

Schedule control

- Annual schedules can be set for each remote controller group / user defined group.
- Start / stop, operating mode, remote controller prohibition, and temperature settings can be set up to 143 times per day at 10 minute intervals for up to 101 configurations for each remote controller group.
- Settings can be made for periods straddling midnight.
- Allows programming of special settings for holidays, including public holidays, for a complete year.
- Low noise operation of outdoor unit can be scheduled.

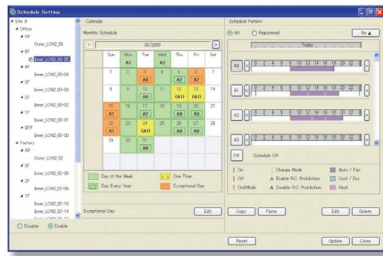

Error display & E-mail notification

Error is notified with popup message, audible sound and E-mail real time when error occurs. Error for the past 1 year are logged and can be reviewed later.

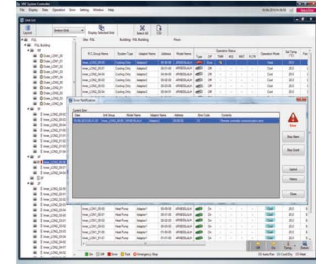

Operating & control record

Displays the history of operation status and control.

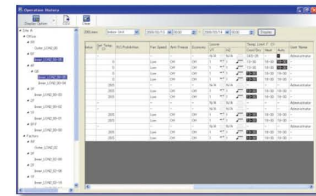

Diverse control of indoor units

- Indoor unit operation state, operation mode, etc. are displayed
- Indoor unit start / stop and operation mode switching
- Temperature setting, Remote Controller prohibition.



Prohibition Setting

This prohibits changes to the operation mode, temperature, start / stop, etc.

Multiple language display

Corresponds to 7 different languages (English, Chinese, French, German, Spanish, Russian, Polish)

Operating Conditions

The following chart shows the detail requirement for an AT compatible personal computer to run System Controller. Applies for both VRF Controller and VRF Explorer PC.

Personal Computer	AT compatible machine that runs Microsoft® Windows®	
Operating System	Microsoft® Windows® XP Professional (Service Pack 3 or later / English version) Microsoft® Windows Vista® Home Premium, Business (Service Pack 2 or later / Corresponds to 7 different languages.*) Microsoft® Windows® 7 Home Premium, Professional (Corresponds to 7 different languages.*) *English, Chinese, French, German, Spanish, Russian, Polish •64-bit version of Windows® are not supported.	
CPU	Intel® Pentium® / Celeron 2 GHz (VRF Controller), 1 GHz (VRF Explorer) or higher	
HDD	40 GB or more of free space (5 GB for VRF Explorer PC)	
Memory	2 GB or more (VRF Controller), 1 GB or more (VRF Explorer)	
Display	1024 x 768 dots or more. 15 inch or higher size is preferable.	
Interface	USB port is required for each of the followings for Server PC ; • Wibu Key (Software protection key) • Echelon® U10 USB Network Interface (Required for each VRF Network) Ethernet port is required for remote connection using internet.	
Accelerator	Requires the internal graphics accelerator be compatible with Microsoft® DirectX® 9.0	
Other Software Required	Adobe® Reader® 9.0 or later	

<OPTION AVAILABLE>

Energy Manager	UTY-PEGX(*1)	Additional support for energy saving function and Electricity Charge Apportionment using electricity meter.
----------------	--------------	---

<PACKING LIST>

Item	Q'ty	Application
CD-ROM	1	Includes the software for System Controller. Both VRF Controller and VRF Explorer software is included.
Wibu Key (Software protection key)	1	Software protection key to be inserted in a USB slot running System Controller. System Controller may only run on a PC with Wibu Key. Remote VRF Explorer software does not require Wibu Key.

Personal computer must be field supplied. U10 USB Network Interface must be field supplied. Contact Echelon® Corporation or its local sales representative for detail.

Product Name : U10 USB Network Interface - TP/FT-10 Channel Model Number : 75010R

*1: Energy Saving Software (UTY-PEGX) is available for the indoor units and the outdoor units after revision code B

Network Converter

UTY-VGGXZ1

Max. connectable
16
single indoor units

Max. connectable
4
Group Remote
Controllers



- This Network Converter is to be used for connecting single split system or Group Remote Controller (UTY-CGGY / UTY-CGGG) with the VRF network system.
- Please select the function by switching the dip switch during the installation.

Functions

Used for connecting single split system

- Split type systems can be centrally controlled from Touch Panel Controller or System Controller through connection to the VRF's network converter.
- On / Off Control, Master control, Room temperature and Fan speed setting via the Network Converter are available.
- One Network Converter can be used to connect and control up to 16 single units.

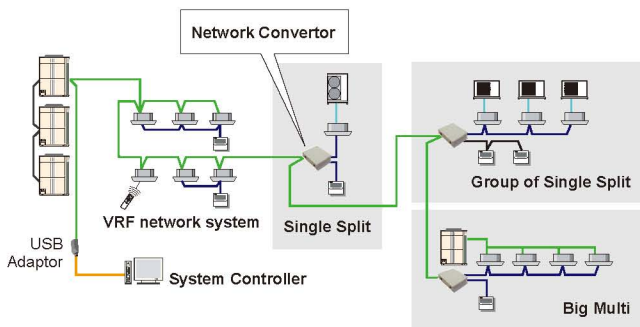

Please consult your distributor for connectable split type air conditioner.
Up to 100 Network Converters may be connected in single VRF network system.
One Network Converter is considered as a single refrigerant system, irrespective of the number of connected single models.

Used for connecting Group Remote Controller

4 Group Remote Controllers can be connected to a single Network Converter (UTY-VGGXZ1).

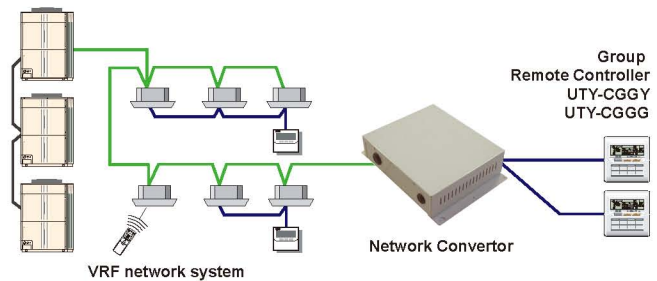

* 2 refrigerant circuits can be covered by a single Network Converter (UTY-VGGXZ1).
Up to a total of 16 Network Converters (UTY-VGGXZ1) and System Controller adaptors can be connected in a single VRF network system.

Specifications

Model name	UTY-VGGXZ1
Power Supply	220-240V 50/60Hz
Power Consumption (W)	8.5
Dimensions (H x W x D) (mm)	67 x 288 x 211
Weight (g)	1,500

Dimensions (Unit : mm)

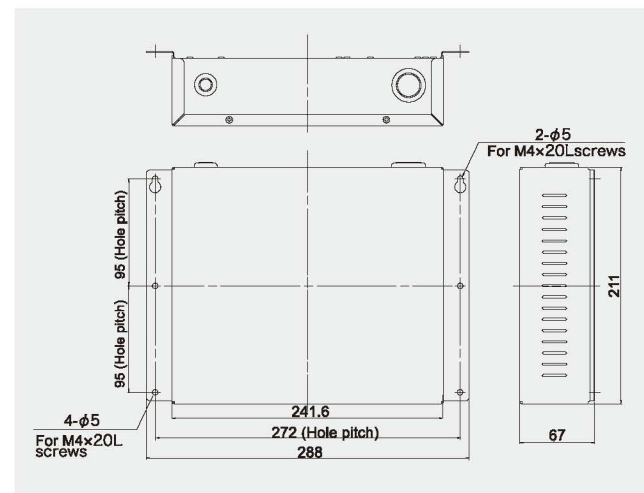

Network Converter for LONWORKS®

UTY-VLGX

Max. controllable
4
Units to BMS

Max. controllable
100
Outdoor units

Max. controllable
128
Indoor units



- For connection between VRF network system and a LONWORKS® open network for management of small to medium-sized BMS and VRF network system.
- The UTY-VLGX permits central monitoring and control of a VRF network system from a BMS through a LONWORKS® interface.
- Up to 128 Indoor units can be connected to one Network Converter for LONWORKS®

Installation example

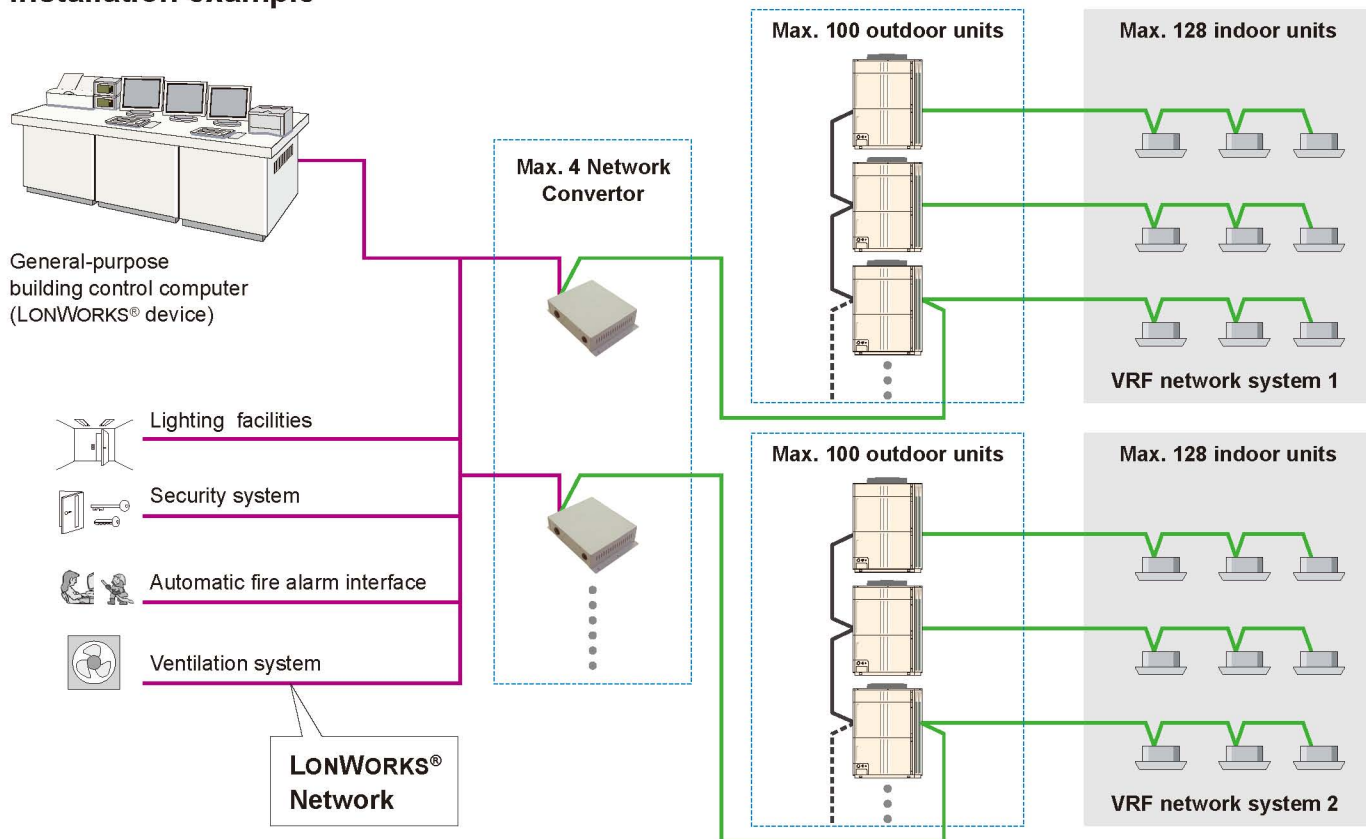

Specifications

Model name	UTY-VLGX
Power Supply	220-240V 50/60Hz
Power Consumption (W)	4.5
Dimensions (H x W x D) (mm)	67 x 288 x 211
Weight (g)	1,500

Transmission specifications (BMS side)

Transmission speed	78 kbps
Transceiver	FT-X1 (Echelon® Corporation)
Transmission way form	Free topology
Terminal resistor	None (It attaches at the terminal of a network.)

Dimensions (Unit : mm)

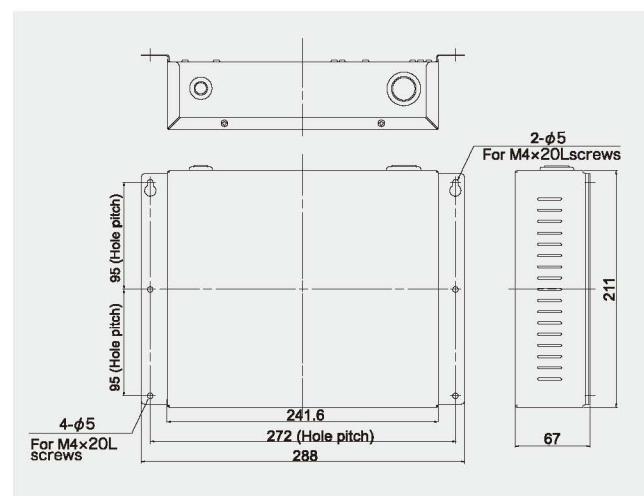

BACnet® Gateway Software

UTY-ABGX

- It is possible to connect medium to large sized BMS to VRF network system via BACnet®, a global standard for open networks.
- A maximum of 1600 indoor units with 4 VRF network systems (a maximum of 400 indoor units & 100 outdoor units for one network system) can be connected to one BACnet® Gateway.
- It is possible to control or monitor VRF network system from BMS via BACnet® Gateway.
- Compatible with BACnet® (ANSI / ASHRAE-135-2004) application specific controller (B-ASC).
- Compatible with BACnet®/IP over Ethernet.
- Scheduling function, Alarm & Event functions as well as Electricity Change Apportionment function are provided in BACnet® Gateway.
- Connection between VRF network system to personal computer is possible via small U10 USB interface. However, both U10 USB interface & personal computer are field supplied items.
- Corresponds to 7 different languages, English, Chinese, French, German, Spanish, Russian, Polish.



CD-ROM (Software)



Software Protection Key

Max. controllable
4
VRF network systems

Max. controllable
400
Outdoor units

Max. controllable
1,600
Indoor units

Installation example

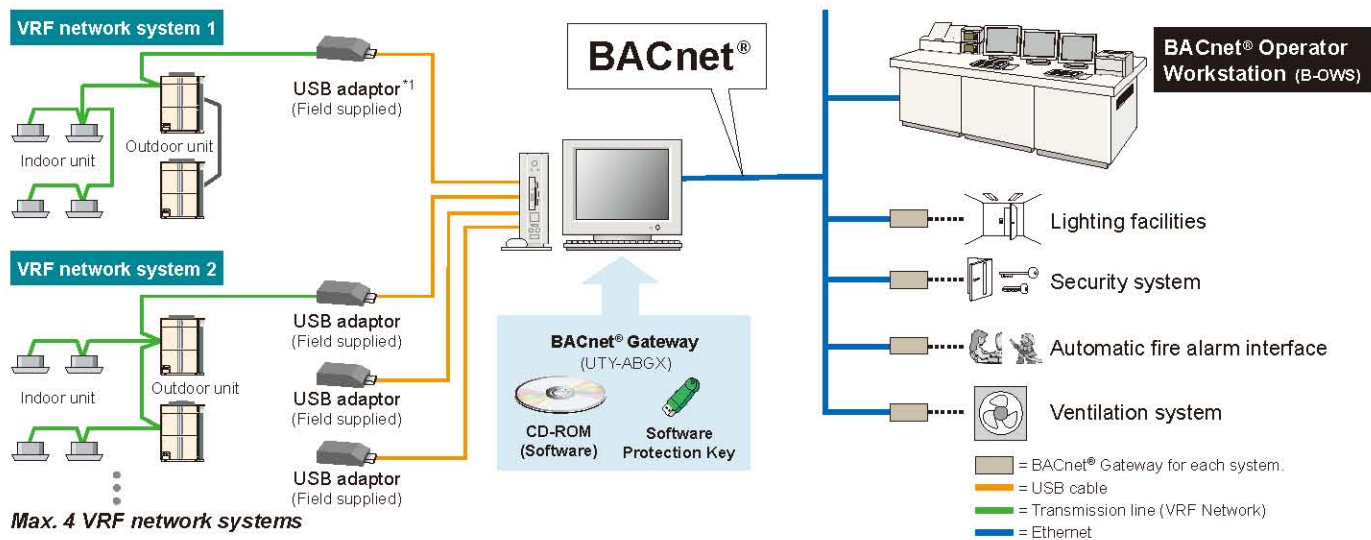

Max. 4 VRF network systems

*1: USB adaptor is U10 USB Network Interface of Echelon® Corporation.

The BACnet Gateway version 2.0 is eligible to display BTL Mark. Founded by BACnet International, BTL (BACnet Testing Laboratories) is an indication of worth trusting for its quality after passing the strict tests.

BTL is a registered trademark of ASHRAE. ASHRAE does not endorse, approve or list products for compliance with ASHRAE standards. Compliance of these products to requirements of ASHRAE Standard 135 is the responsibility of the BTL user. BTL is a registered trademark of BACnet International.

PERSONAL COMPUTER SPECIFICATIONS

	For BACnet® Gateway (UTY-ABGX)
CPU	At compatible machine that runs Microsoft® Windows® Intel® Pentium® / Celeron®, AMD Athlon / Duron processor 2 GHz or higher
Hard Drive	40 GB or more of free space
Memory	2 GB or more
Display	1024 x 768 dots or more, High color (16bit) or more
Interface	USB port (x 2-5) is required Ethernet port is required
Operating System	Microsoft® Windows® XP Professional (Service Pack 3 or later / English version) Microsoft® Windows Vista® Home Premium, Business (Service Pack 2 or later / Corresponds to 7 different languages.*) Microsoft® Windows® 7 Home Premium, Professional (Corresponds to 7 different languages.*) *English, Chinese, French, German, Spanish, Russian, Polish •64-bit version of Windows® are not supported.
Required Hardware	CD-ROM drive
Required Software	Adobe® Reader® 9.0 or later

<PACKING LIST>

Packing List	CD-ROM / Wibu Key
--------------	-------------------

Personal computer must be field supplied. U10 USB Network Interface must be field supplied. Contact Echelon® Corporation or its local sales representative for detail.
Product Name : U10 USB Network Interface - TP/FT-10 Channel Model Number : 75010R

Signal Amplifier

UTY-VSGX

- Transmission Line length can be extended up to 3,600m with multiple Signal Amplifiers.
- Up to 8 signal amplifiers can be installed in a VRF network system.
- A signal amplifier is required,
 - (1) When the total wiring length of the transmission line exceeds 500m.
 - (2) When the total number of units on the transmission line exceeds 64.



Installation example

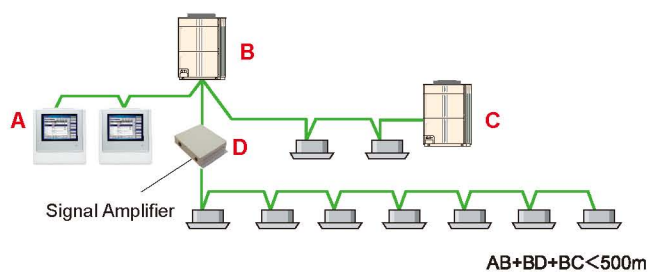

Specifications

Model name	UTY-VSGX
Power Supply	220-240V 50/60Hz
Power Consumption (W)	4.5
Dimensions (H x W x D) (mm)	67 x 288 x 211
Weight (g)	1,500

Dimensions (Unit : mm)

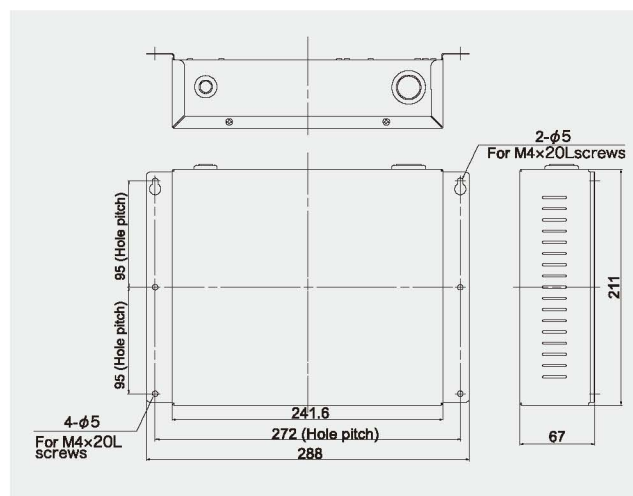

External Switch Controller

UTY-TEKX

Air conditioner switching can be controlled by connecting other sensor switches

- In combination with a field supply Card-Key Switch or other sensor, the External Switch Controller allows control of the ON / OFF, Room temperature, Fan speed and Master control functions. This makes this product suitable for installations such as hotel rooms.
- Card-key or other sensor switches are available as a field supplied parts.

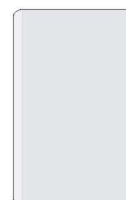

Installation example

Auto mode operation, which switches the cooling and the heating automatically, is enabled by using the sensor switch and External Switch Controller.

Note: All indoor units will operate in the same mode.

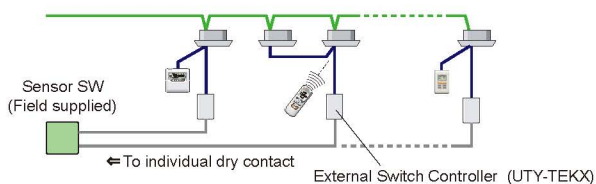
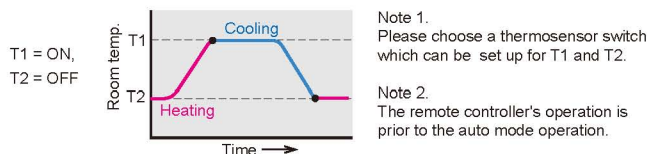

Electrical wiring

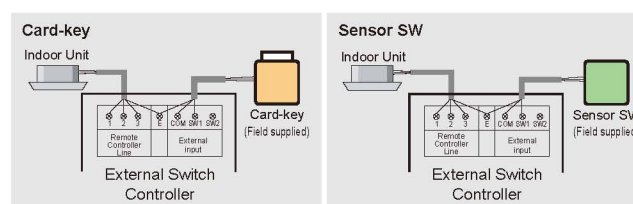

Specifications

Model name	UTY-TEKX
Power Supply	DC 12V
Dimensions (H x W x D) (mm)	120 x 75 x 30
Weight (g)	90

DC12V is supplied by the indoor unit.

Service Tool Software

UTY-ASGX

Max. Monitor and control
100
Outdoor units

Max. Monitor and control
400
Indoor units

Extensive monitoring and analysis functions for installation and maintenance.

- Operation status can be checked and analyzed to detect even the small abnormalities.
 - Data collected and stored on site can be checked later, off-line, off-site for more detail analysis.
 - One VRF network system with maximum number of up to 400 units can be monitored and controlled.
 - Operation status and various sensor information can be monitored and checked real time in the form of list, refrigerant circuit diagram, graphs as well.
 - Simple operation control functions are useful during maintenance.
 - The recent error history can be retrieved from units on demand to perform analysis on the cause of the error, after connecting Service Tool to the VRF network system.
 - Commissioning tool supports test runs, data storage for each unit and saving of data as CSV files, which may be formatted to create commissioning report.
 - Connectable to any point of transmission line with USB adaptor*1 (field supplied)
 - Connection between VRF network system to personal computer is possible via small U10 USB interface. However, both U10 USB interface & personal computer are field supplied items.
 - New 8 functions are added for V-II series and service performance is advanced furthermore. (supported by Ver. 1.1 or later)
- * 1: Service Tool (UTY-ASGX) will only support USB type network adaptor and will not support transmission adaptor of the traditional type(UTR-YTMA)



Wiring connection

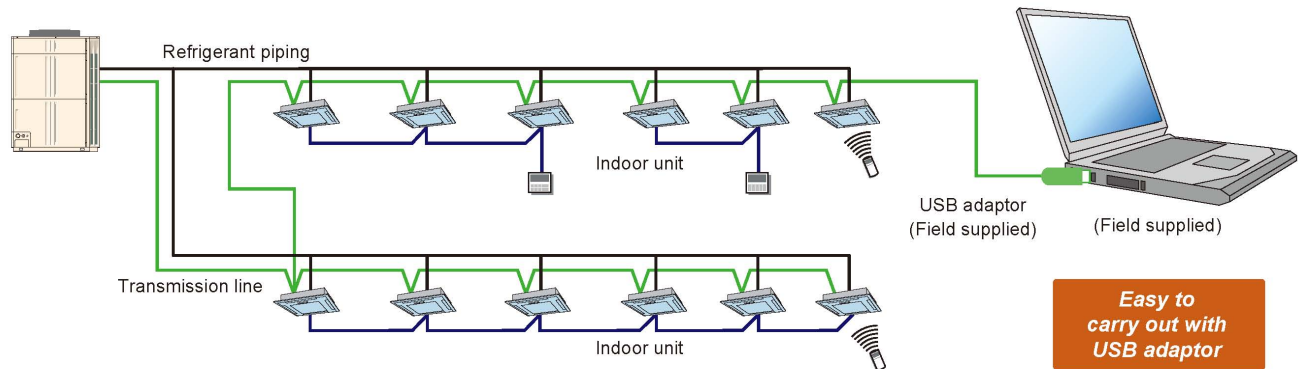

*USB Adaptor is U10 USB Network interface of Echelon® Corporation.

Easy to carry out with USB adaptor

Functions

1) System List

Displays the overall operation status of all or specified units in the system in a list form.

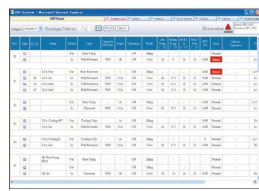

2) Equipment Detail (Diagram)

Displays the detail information for sensor values, electrical components etc. for the specified units in schematic. The information here can be used along with the detail information in list form, to check the operation status of units and make detail analysis on the cause, in case an error occurs.

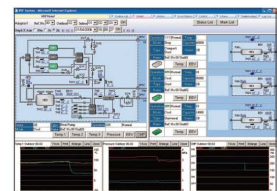

3) Equipment Detail (List)

Displays the detail information for sensor values, electrical components etc. of units in a specified refrigerant system in list form. The information here can be used along with the detail information in diagram form, to check the operation status of units and make detail analysis on the cause, in case an error occurs.

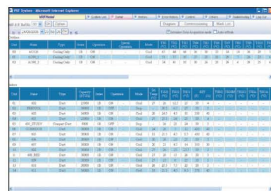

4) Operation History

The indoor units or outdoor unit operation history can be recorded. The displayed operation history can be printed out and saved to a CSV file.

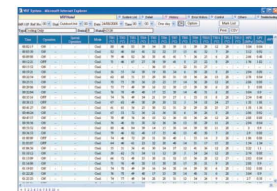

5) Error History

Displays the error information for each unit. The error information can sequentially be displayed up to 50 items as they occur starting with the latest error.

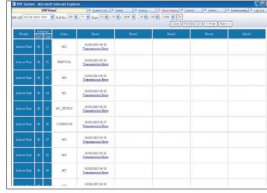

6) Remote File Download

Operation and error history data can be downloaded. Only the required data may be downloaded specifying the refrigerant system, unit and time range.

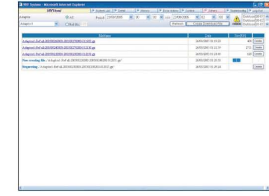

7) Commissioning Tool

Test run commands can be executed with this tool. During test running, the outdoor unit / indoor unit sensor data can be saved (commissioning log data). After the end of test running, this data can be exported in CSV file format.

8) Network Topology Analyzer *

A list of units connected to the VRF system network is displayed in network segments in tree form.



9) Remote Setting *

Function (Field) Setting for indoor unit is realized remotely

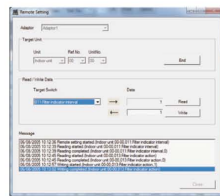

10) System Time Setting *

An arbitrary time is set for all the remote controllers within the system.

11) Software Version *

The software version of units are acquired and displayed.

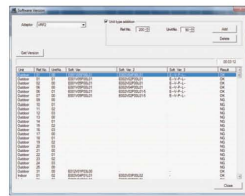

12) Central Release *

The operation setting restriction function of the indoor units set from the controller can be forcibly released. (remote controller inhibit, temperature upper/lower limit setting)

13) Model Name Writer *

An arbitrary model name can be written to the target unit.

14) Error Memory Reader *

When an error occurs at an outdoor unit, the operation data records before the error are acquired over a network and saved to a CSV file.

Note: To perform "Error Memory Reading", Service Tool and the corresponding outdoor unit must be connected directly with each other. Refer to the Operation Manual of the Service Tool for detail.

15) Time Guard Information *

Reference data for judging the maintenance period of indoor and outdoor units (compressor, FAN, etc. integrated time) is output to a CSV file.

*: Supported by Ver. 1.1 or later

PERSONAL COMPUTER SPECIFICATIONS

Operating System	AT compatible machine that runs Microsoft® Windows® Microsoft® Windows® XP Professional (English version / Service pack 3 or later) Microsoft® Windows® Vista® Home Premium, Business Edition (English version) Microsoft® Windows® 7 Professional (English version) *64-bit version of Windows® are not supported.
CPU	Intel® Pentium® / Celeron®, AMD Athlon™ / Duron™ 1 GHz or higher
HDD	10 GB or more of free space
Memory	1 GB (Vista, 7), 512 MB (XP) or more
Interface	USB port for U10 USB Network Interface and Software protection key.
Required Software	Internet Explorer 6.0 or 7.0 or 8.0 / Adobe® Reader® 9.0 or later
Required Hardware	CD-ROM drive

<PACKING LIST>

Packing List	CD-ROM / Wibu Key
--------------	-------------------

Personal computer must be field supplied. U10 USB Network Interface must be field supplied. Contact Echelon® Corporation or its local sales representative for detail.
Product Name : U10 USB Network Interface - TP/FT-10 Channel Model Number : 75010R

Web Monitoring Tool

Software

UTY-AMGX

4
VRF network systems
can be supported

1600
Indoor unit
can be monitored

Product features

- Troubleshooting is performed by monitoring each unit remotely during periodical system checks off-site.
- Operation status can be checked and analyzed to detect even the smallest abnormalities.
- Four VRF network systems each with 400 units, with maximum number of up to 1,600 units can be monitored and controlled.
- Operation status and various sensor information can be monitored and checked real time in the form of list, refrigerant circuit diagram, and graphs as well.
- The monitoring data in a remote side can be optionally downloaded. And, this data can be displayed in off-line mode of the Service Tool.
- Error notification can be automatically transmitted to several locations using the internet^{*1}.
- Monitoring side computer is not required to install special software, requires only general web browser.
- Connectable to any point of transmission line with U10 USB interface^{*2} (field supplied)
- Connection between VRF network system to personal computer is possible via small U10 USB interface. However, both U10 USB interface & personal computer are field supplied items.
- New 6 functions are added for V-II series and service performance is advanced furthermore. (supported by Ver. 1.1 or later)

* 1: USB of internet mail system required.

* 2: Web Monitoring Tool (UTY-AMGX) will only support USB type network adaptor and will not support transmission adaptor of the traditional type (UTR-YTMA).

Web Monitoring System

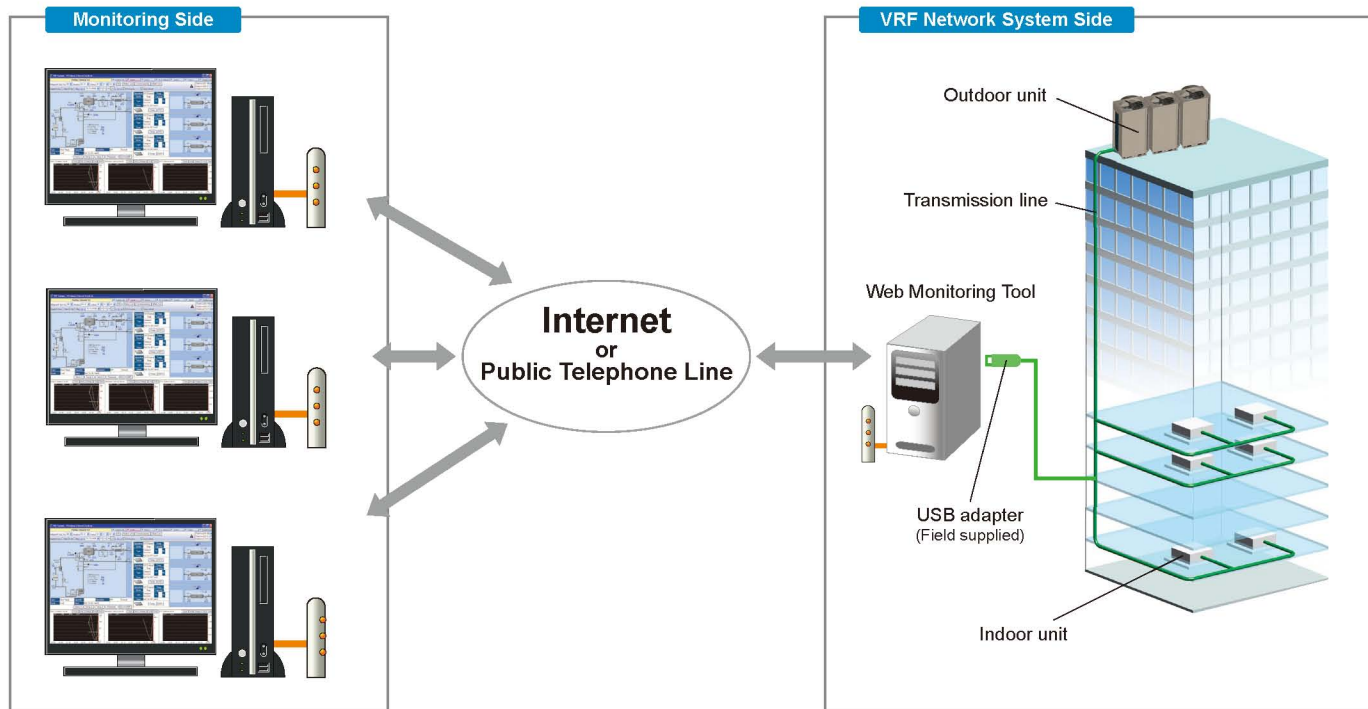

System components

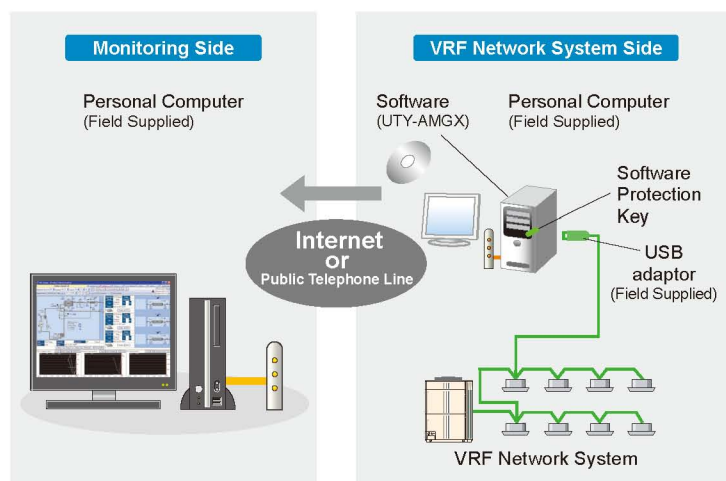

Support 4 VRF network systems

USB adaptor (max. 4 adaptors per PC) permit, monitoring of up to 1,600 indoor units.
Suitable for large-scale buildings or hotels.

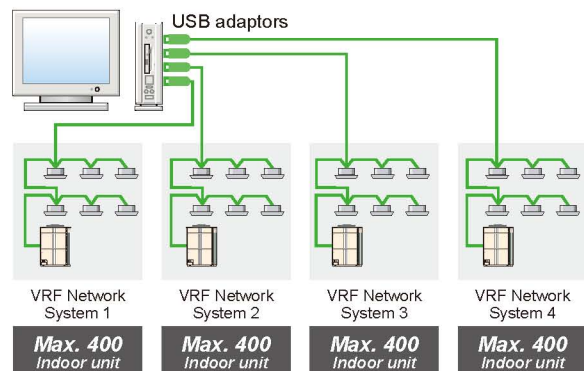

COMPARISON TABLE

No.	Item	Service Tool UTY-ASGX	Web Monitoring Tool UTY-AMGX	
			VRF network system Side	Monitoring Side
1	Interchangeability of equipment	●	●	●
2	Indication of equipment list	●	●	●
3	Operation control	●	●	—
4	Indication of refrigerant circuit diagram	●	●	●
5	Commissioning tool	●	●	—
6	Monitoring of equipment information	●	●	●
7	Monitoring of operating condition	●	●	●
8	Monitoring of sensor data	●	●	●
9	Storage and CSV output of operating history (sensor data)	●	●	●
10	Indication of trend graph	●	●	●
11	Printing of trend graph	●	●	●
12	Monitoring and screen display of abnormalities	●	●	●
13	E-mail automatic transmission of abnormalities	—	● ^{*1}	—
14	Setting for user level	—	●	—
15	Network Topology Analyzer *	●	●	—
16	Remote Setting *	●	●	—
17	System Time Setting *	●	●	—
18	Software Version *	●	●	—
19	Central Release *	●	●	—
20	Model Name Writer *	●	—	—
21	Error Memory Reader *	●	—	—
22	Time Guard Information *	●	●	●

*: Supported by Ver. 1.1 or later

*1: it is available only during a connection to the Internet.

PERSONAL COMPUTER SPECIFICATIONS

Operating System	AT compatible machine that runs Microsoft® Windows® Microsoft® Windows® XP Professional (English version / Service pack 3 or later) Microsoft® Windows® Vista® Home Premium, Business Edition (English version) Microsoft® Windows® 7 Professional (English version) *64-bit version of Windows® are not supported.
CPU	Intel® Pentium® / Celeron®, AMD Athlon™ / Duron™ 1 GHz or higher
HDD	40GB or more of free space
Memory	1 GB or more
Interface	USB port (for U10 USB Network Interface Max.4 , Software protection key) Following interface is required for remote connection: Public Telephone Line : Modem is required Internet using LAN : Ethernet port is required
Required Software	Internet Explorer 6.0 or 7.0 or 8.0 / Adobe® Reader® 9.0 or later
Required Hardware	CD-ROM drive

<PACKING LIST>

Packing List	CD-ROM / Wibu Key
--------------	-------------------

Personal computer must be field supplied. U10 USB Network Interface must be field supplied. Contact Echelon® Corporation or its local sales representative for detail.
Product Name : U10 USB Network Interface - TP/FT-10 Channel Model Number : 75010R

Energy Recovery Ventilator

Models

- UTZ-BX025A
- UTZ-BX035A
- UTZ-BX050A
- UTZ-BX080A
- UTZ-BD100A



Energy recovery ventilator unit offers maximum comfort and greater energy savings.

Heat exchange ventilation and normal ventilation

Heat exchange ventilation

When a room is cooled or heated, the exhausted cooling / heating energy is recovered by heat-exchange ventilation.

Normal ventilation

This is used in spring and autumn, when rooms are not cooled or heated, that is, when there is little difference between the indoor and outdoor air conditions. In addition, at night during the hot season, when the outside air temperature drops the outside air is drawn inside without heat exchange, alleviating the load on the air conditioning equipment.

Adopts a highly efficient counter-flow heat exchange element

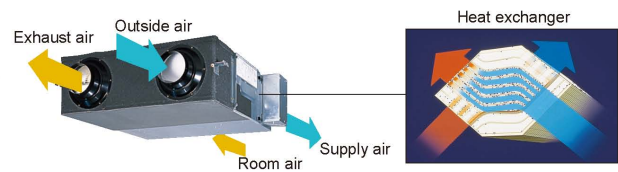

Specifications

Rated flow rate			250 m³/h	350 m³/h	500 m³/h	800 m³/h	1000 m³/h	
Model No.			UTZ-BX025A	UTZ-BX035A	UTZ-BX050A	UTZ-BX080A	UTZ-BD100A	
Power source			220 - 240V, 50Hz					
HEAT EXCHANGE VENTILATION	Input power	(Extra high) / High / Low	W	119 / 99 / 79	154 / 124 / 117	214 / 169 / 151	347 / 309 / 302	445 / 360 / 332
	Air flow rate	(Extra high) / High / Low	m³/h	250 / 250 / 170	350 / 350 / 280	500 / 500 / 370	800 / 800 / 650	1,000 / 1,000 / 810
	External static pressure	(Extra high) / High / Low	Pa	90 / 80 / 37	95 / 65 / 42	105 / 70 / 38	140 / 110 / 70	90 / 55 / 35
	Temperature Exchange Efficiency	(Extra high) / High / Low	%	75 / 75 / 77	75 / 75 / 77	75 / 75 / 77	75 / 75 / 76	75 / 75 / 76
	Energy Exchange Efficiency Cooling	(Extra high) / High / Low	%	63 / 63 / 66	66 / 66 / 69	62 / 62 / 67	65 / 65 / 68	65 / 65 / 68
	Energy Exchange Efficiency Heat pump	(Extra high) / High / Low	%	70 / 70 / 73	69 / 69 / 71	67 / 67 / 71	71 / 71 / 74	71 / 71 / 73
	Sound pressure level	(Extra high) / High / Low	dB*	28 / 26 / 21	32 / 29 / 25	34 / 31 / 25	38 / 36.5 / 32	37.5 / 36 / 31
NORMAL VENTILATION	Input power	(Extra high) / High / Low	W	119 / 98 / 79	151 / 119 / 113	210 / 161 / 145	337 / 300 / 297	438 / 358 / 329
	Air flow rate	(Extra high) / High / Low	m³/h	250 / 250 / 170	350 / 350 / 280	500 / 500 / 370	800 / 800 / 650	1,000 / 1,000 / 810
	External static pressure	(Extra high) / High / Low	Pa	90 / 80 / 37	95 / 65 / 42	105 / 70 / 38	140 / 110 / 70	90 / 55 / 35
	Sound pressure level	(Extra high) / High / Low	dB*	27 / 26.5 / 21.5	31 / 30 / 26	34 / 32 / 26.5	38.5 / 37 / 33	38 / 36.5 / 31.5
Dimensions (W × D × H)	mm		882 × 599 × 270	882 × 804 × 270	962 × 904 × 270	1,322 × 884 × 388	1,322 × 1,134 × 388	
Weight	kg		29	37	43	71	83	
Outlet duct diameter	mm		150	150	200	250	250	
Operation range	°C		-10 to 40	-10 to 40	-10 to 40	-10 to 40	-10 to 40	
Maximum humidity	%		85	85	85	85	85	

* The noise level must be measured 1.5 m below the centre of the unit.

Energy efficiency and ecology

Energy consumption is dramatically reduced by using a counterflow heat-exchange element. Air conditioning load is reduced by approximately 20%, resulting in significant energy savings. Recovers up to 77% of the heat in the outgoing air.

20%
Energy saving

Features of heat exchange element

With the cross-flow element, air moves in a straight line across the element. With the counter-flow element, air flows through the element for a longer time (longer distance), so the heat-exchange effect remains unchanged.

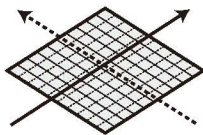

Other element
(Cross-flow element)

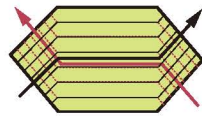

Fujitsu element
(Counter-flow element)

Features of heat exchange element

Significantly reducing low pressure loss and noise allows low-noise operation of 32 dB (High) or less for models with a capacity of 500 m³/h or less, and 37.5 dB (High) for models with a capacity of 1,000 m³/h.

Long heat-exchanger service life

Cleaning reduced due to the special material heat exchanger. The nylon/polyester fibre filter offers high dust retention capacity.

Slim shape and easier installation

Counter-flow heat exchange element used for reduced noise and slimmer, more compact body shape.



UTZ-BX025A/BX035A/BX050A

UTZ-BX080A/BD100A

Reverse mountable direct air supply / exhaust system

Adoption of straight air supply / exhaust system: Duct design is simplified because the air supply / exhaust ducts are straight.

Since each unit can be mounted in reverse position, only one inspection hole is needed for two units: Two units can share one inspection hole so duct work is easier and more flexible.

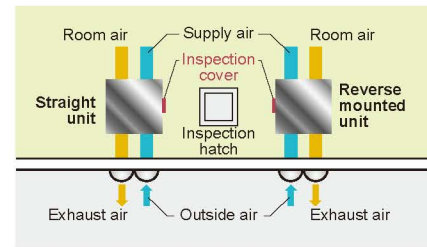

Dimensions (Unit: mm)

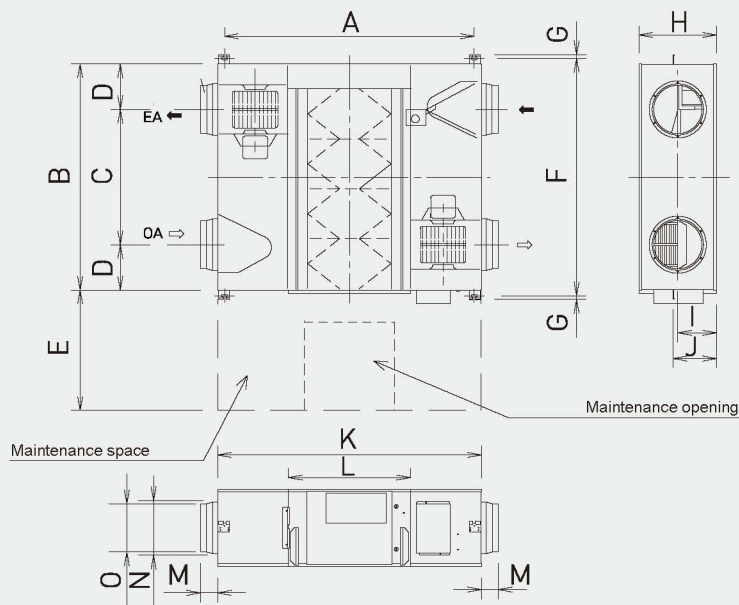

Models: UTZ-BX025A / UTZ-BX035A / UTZ-BX050A / UTZ-BX080A / UTZ-BD100A



	UTZ-BX025A	UTZ-BX035A	UTZ-BX050A	UTZ-BX080A	UTZ-BD100A
A	810	810	890	1,250	1,250
B	599	804	904	884	1,134
C	315	480	500	428	678
D	142	162	202	228	228
E	600	600	600	600	600
F	655	860	960	940	1,190
G	19	19	19	19	19
H	270	270	270	388	388
I	135	145	145	194	194
J	159	159	159	218	218
K	882	882	962	1,322	1,322
L	414	414	414	612	612
M	95	95	107	85	85
N	219	219	246	258	258
O	144	144	194	242	242

Optional Parts

Controllers

<p>Wired Remote Controller UTY-RNK*</p> 	<p>Simple Remote Controller UTY-RSK* With operation mode</p> 	<p>Simple Remote Controller UTY-RHK* Without operation mode</p> 
<p>Wireless Remote Controller UTY-LNH*</p> 	<p>IR Receiver Unit UTB-YWC UTB-TWC</p>  <p>For All Duct type</p>	<p>IR Receiver Kit UTY-LRHYB1 UTY-LRHGB1</p>  <p>For Cassette type</p>
<p>Group Remote Controller UTY-CGG*</p> 	<p>Central Remote Controller UTY-DCG*</p> 	<p>Touch Panel Controller UTY-DTG*</p> 
<p>System Controller Software UTY-APGX</p> 		



K*: KY (FUJITSU), KYT (FUJITSU), KG (GENERAL) H*: HY (FUJITSU), HG (GENERAL) G*: GY (FUJITSU), GG (GENERAL)

Convertors / Adaptors

<p>Network Converter UTY-VGGXZ1</p> 	<p>Network Converter for LONWORKS® UTY-VLGX</p> 	<p>BACnet® Gateway Software UTY-ABGX</p>  <p>CD-ROM (Software) Software Protection Key</p>
<p>Signal Amplifier UTY-VSGX</p> 	<p>External Switch Controller UTY-TEKX</p> 	

Optional Parts

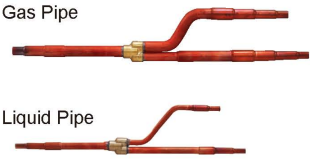
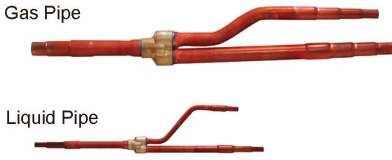
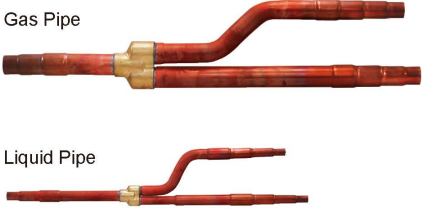
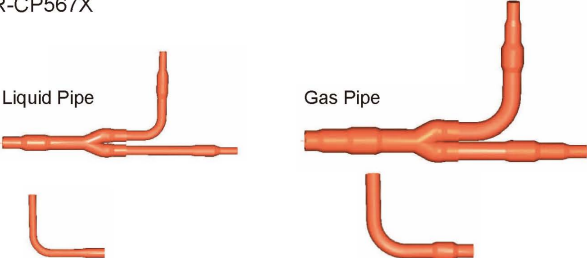
Connection Tube

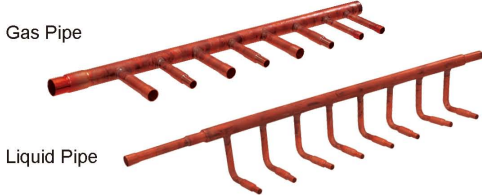
<p>Separation Tube UTR-BP090X</p>  <p>Gas Pipe</p> <p>Liquid Pipe</p>	<p>Separation Tube UTR-BP180X</p>  <p>Gas Pipe</p> <p>Liquid Pipe</p>
<p>Separation Tube UTR-BP567X</p>  <p>Gas Pipe</p> <p>Liquid Pipe</p>	<p>Outdoor Unit Branch kit UTR-CP567X</p>  <p>Liquid Pipe</p> <p>Gas Pipe</p>
<p>Header UTR-H0906L UTR-H1806L</p>  <p>Gas Pipe</p> <p>Liquid Pipe</p>	<p>Header UTR-H0908L UTR-H1808L</p>  <p>Gas Pipe</p> <p>Liquid Pipe</p>

Specifications

Outdoor unit Branch kit

Model name	UTR-CP567X	
Number of Outdoor unit	2 outdoor units	1
	3 outdoor units	2

Separation Tube

Model name	UTR-BP090X	UTR-BP180X	UTR-BP567X
Total cooling capacity of indoor unit (kW)	28.0 or less	28.1 to 56.0	56.1 or more

Header

Model name	3-6 Branches	UTR-H0906L	UTR-H1806L
	3-8 Branches	UTR-H0908L	UTR-H1808L
Total cooling capacity of indoor unit (kW)		28.0 or less	28.1 to 56.0

EV Kit

Model name	UTR-EV09XB	UTR-EV14XB
Application Model	AS*E07LACH AS*E09LACH	AS*E12LACH AS*E14LACH

AS* : ASY(FUJITSU), ASH(GENERAL)

Others

<p>Flange (Round) UTD-RF204 For Low Static Pressure Duct type / Duct type / Ceiling type</p> 	<p>Flange (Square) UTD-SF045T For Low Static Pressure Duct type / Duct type</p> 	<p>Remote Sensor Unit UTD-RS100 For All Duct type</p> <p>New amenity space can be offered by installing the Remote sensor.</p> 
<p>Long-Life Filter UTD-LF25NA For Low Static Pressure Duct type / Duct type</p> 	<p>Long-Life Filter UTD-LF60KA For ARXC36/45/60LATH</p> 	<p>Auto Louver Grille Kit UTD-GXSA-W (for ARXD07/09/12/14LATH) UTD-GXSB-W (for ARXD18LATH) UTD-GXSC-W (for ARXD24LATH) For Slim Duct type</p> 
<p>Drain Pump Unit UTZ-PX1BBA For Compact Duct type</p> <p>UTZ-PX1NBA For Low Static Pressure Duct type / Duct type</p> 	<p>Drain Pump Unit UTR-DPB24T For Ceiling type</p> 	<p>Wide Panel UTG-AGYA-W For Cassette type</p>  <p>Indoor unit 950 Panel 600 600 (mm)</p>
<p>Air Outlet Shutter Plate UTR-YDZB For Compact Cassette type</p> <p>Shuts the air outlet when only using as 3 blow out.</p> 	<p>Air Outlet Shutter Plate UTR-YDZC For Cassette type</p> <p>Shuts the air outlet when only using as 3 blow out.</p> 	<p>Panel Spacer UTG-BGYA-W For Cassette type</p>  <p>50mm Panel spacer</p>
<p>Grille Kit UTG-UFYC-W UTG-UFGC-W</p> <p>For Compact Cassette type</p> 	<p>Grille Kit UTG-UGYA-W UTG-UGGA-W</p> <p>For Cassette type</p> 	<p>Insulation Kit for High Humidity UTZ-KXGA For Cassette type UTZ-KXGB For Slim Cassette type UTZ-KXGC For Compact Cassette type</p> <p>Insulation Kit</p> 
<p>Fresh Air Intake Kit UTZ-VXAA</p> <p>For Compact Cassette type</p> 	<p>Fresh Air Intake Kit UTZ-VXGA</p> <p>For Cassette type</p> 	<p>EV Kit Model code < 09 : UTR-EV09XB Model code ≥ 12 : UTR-EV14XB</p> <p>For Compact Wall Mounted type</p> 

FUJITSU GENERAL LIMITED

1116, Suenaga, Takatsu-ku, Kawasaki 213-8502, Japan
<http://www.fujitsu-general.com/>



ISO 9001 Certified number: 01 100 89394
ISO 14001 Certified number: 01 104 9245101
Fujitsu General (Thailand) Co., Ltd.



ISO 9001 Certified number: 01 100 79269
Fujitsu General (Shanghai) Co., Ltd.



ISO 14001 Certified number: 272043
Fujitsu General (Shanghai) Co., Ltd.



ISO 9001 Certified number: 00608G11061R2M
ISO 14001 Certified number: 00609E20454R2M
Fujitsu General Central Air-conditioner (Wuxi) Co., Ltd.



All products specified in this brochure comply with the Australian Communications Authority's (ACA) requirements for Electromagnetic

"**AIRSTAGE™**" is a worldwide trademark of FUJITSU GENERAL LIMITED and is a registered trademark in Japan, the U.S.A and other countries or areas.

*Microsoft® and Windows® are registered trademarks of Microsoft Corporation in the United States.

*Adobe® Reader® are registered trademarks of Adobe Systems Incorporated in the United States.

*Intel®, Pentium® and Celeron® are registered trademark of Intel Corporation or its subsidiaries in the United States.

*AMD Athlon™ and AMD Duron™ are registered trademark of Advanced Micro Devices, Inc.

*Echelon®, LONWORKS®, and the Echelon logo are trademarks of Echelon Corporation registered in the United States and other countries.

*BACnet® is a registered trademark of the American Society of Heating Refrigeration and Air Conditioning Engineers (ASHRAE).

The colors may be different from the actual colors because this catalog is printed matter.

Product specifications are subject to change without notice.

Distributed by : **Alpha Appliances Limited**
<http://www.alpha-general.com>